

Insulated Conductor Rail

SinglePowerLine Program 0812

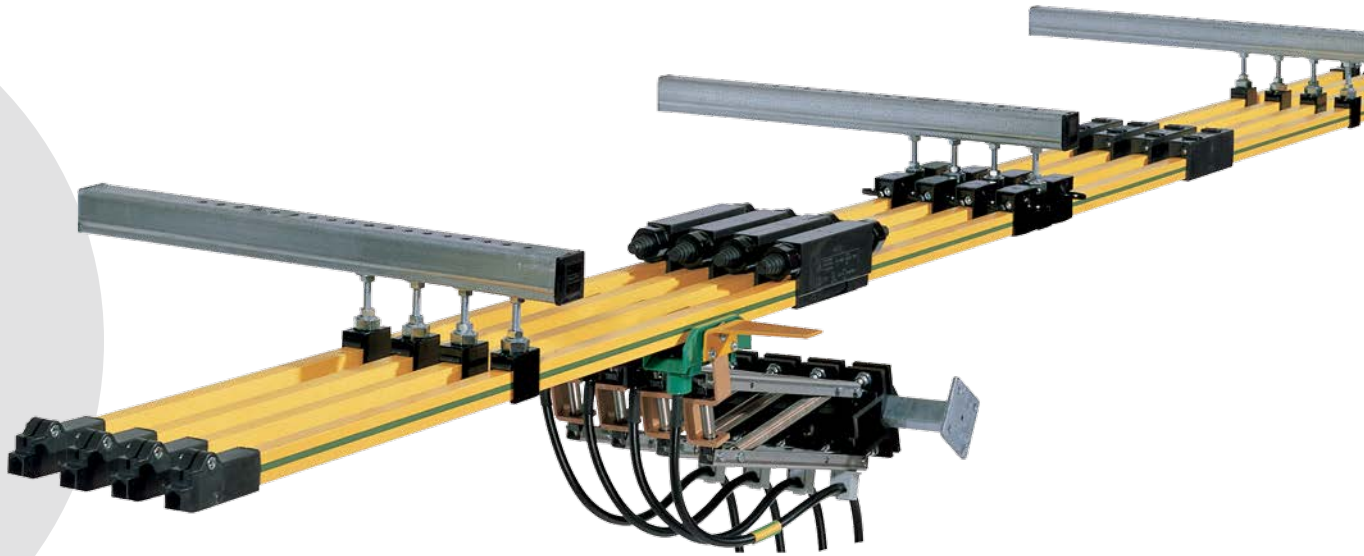

CONDUCTIX
wampfler

© DELACHAUX GROUP

Table of Contents

System Description	5
Technical Data	6
General Instructions	7
System Structure	8
Components and their use	8
Insulated Conductor Rails	9
Clamps and Connectors	10
Hanger Clamps	10
Compact Hanger Clamps	11
Anchor Clamps	11
Rail Connectors	12
Power Feed Connectors	12
End Caps	13
Air Gaps	13
Expansion Units	14
Expansion Units	14
Pickup Guide for Intersections	16
Current Collectors	17
Current Collectors (Plastic Arm Type)	17
Current Collectors (Parallel Arm Metal Type)	18
Installation spacing for Current Collectors	18
Dual Current Collectors (Parallel Arm Metal Type)	19
Installation Instructions and Assembly Help for Current Collectors	20
Dimensioning and Layout of Conductor Rail System	22
System Layout	25
Layout Schematic and Component Overview	26
Example Material Overview / Example Order	26
Mounting Accessories	27
Support Arms 30 × 32 × 2 mm - perforated	27
Support Arms 40 × 40 × 2.5 mm - perforated	27
Permissible Load for Support Arms	27
Holders for Support Arm 30 × 30 × 2 for Screw Mounting with 2-holed Connector Plate	28
Holders for Support Arm 40 × 40 × 2.5 for Screw Mounting with 2-holed Connector Plate	28
Girder Clips, Clamping Thickness 4 - 20 mm	29
Girder Clips, Clamping Thickness 18 - 36 mm	29
Girder Clips, non-twistable, Clamping Thickness 6 - 25 mm	29
Towing Arms	30
End Caps	30
Insulators	30
Notch-type Cable Lugs for Power Feed Line	31
Connector Cables for Current Collector Head 081209	31
Spring Assembly (lateral insertion) for Current Collector Head 081209	31
Tools and Assembly Accessories	32
Mounting Comb 081045	32
Bending Device 081010	32
Contact Grease for Connection Points	32
Replacement Parts	33
Complete Current Collector Head for Current Collector 081209	33
Stabilization Springs for Current Collector Head 081209	33
Replacement Copper Graphite Shoes with insulation for Current Collector Head 081205... / 081206... / 081207... / 081208...	33
Replacement Parts for Current Collectors	34

System Description

The SinglePowerLine 0812 conductor rail system is used as a standard product to power bridge, portal and process cranes, but can also be used in a wide variety of other applications such as amusement rides and people movers. For over 35 years, it is a specified, reliable, and approved product in these applications.

As an insulated single-pole safety conductor rail, the contact-protected system meets requirements for conductor rails according to European (CE) and current international standards.

With different insulation materials, the 0812 system can be used with applications with conductor temperatures of up to 115 °C. This is equivalent to a constant ambient temperature of 85 °C at 100% duty cycle under continuous load. The conductor rail can temporarily withstand up to 125 °C.

For conductor materials, copper and stainless steel are available, as well as aluminum in seawater-resistant alloys with stainless steel contact surfaces.

With the partial expansion compensation system (compensation for thermal expansion in every rail part), systems up to 200 m in length can be implemented without the use of additional expansion elements.¹⁾

The safe, refined connector system and clip-on rail holders, in combination with optional mounting brackets, permit fast, economical assembly.

With the SinglePowerLine 0812 system and the 0813 product line extension for higher power ranges, Conductix-Wampfler offers a reliable, proven and robust solution for your application. Present around the world, our representatives and sales partners will be at your side from planning to implementation and service.

The plastic insulation of the conductor rails is colored safety yellow in accordance with general marking regulations, and the PE ("grounding") conductor rail components are green and yellow (continuous green color strips). Other colors are available upon request, with minimum order quantities.

Safety conductor rail with a finger-safe design. Testing of contact protection with IEC / UL / NEMA jointed test fingers (12 mm foreign bodies).

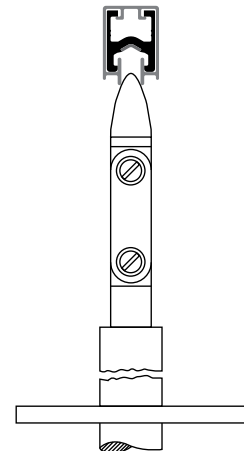



System Advantages:

- Available in different conductor materials
- Finger-safe design
- Used around the world
- Modular, expandable system
- Can be formed into circular slip rings and curves either at the factory or on site
- Self-extinguishing insulation compliant with UL-94 standard
- Yellow safety-color
- Designed for 100% duty cycle according to European standards
- Self-aligning hanger clamps
- Seawater-resistant
- Special seamless and corrosion-resistant process for connection of aluminum rails and stainless steel contact surfaces

¹⁾ Take arrangement and ambient temperature into consideration.

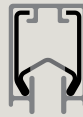
Technical Data

Conductor Rails	Aluminum		Copper		Stainless Steel
Type	081213	081214	081215	081216	081217
Current load [A] At 100% duty cycle and 35 °C (rated value) At 60% duty cycle and 20 °C	200 260	 320 380	 250 320	 400 480	 25 32
Rated voltage [V]	690 (UL 660 V) – min. 24 V / 1A (minimum load)				
Protection type	Vertical insertion of Current Collector: IP23 (DIN EN 60529, VDE 0470-1); horizontal insertion of Current Collector: IP21				
Safety level	Finger-safe design				
Installation orientation	Horizontal with collector entry on bottom side; collector entry sideways optional, for indoor use only				
Application area	Cranes, people movers, and similar applications				
Environment	Indoors and outdoors (see protection class)				
Rated suspension spacing [m]	1.5 (59.1 inches) typically 1.4 to 1.5				
Rail length [mm]	4000 (157.5 inches) (rated dimensions at 20 °C / tolerance ± 3 mm)				
System length [m]	unlimited (depending on power feed design, temperature, and expansion connectors)				
Exterior dimensions [mm]	18 x 26 (rail cross section)				
Rated rail spacing [mm]	50 (1.97 inches) (minimum spacing can be extended as needed)				
Travel speed [m/min]	600 m/min (straight segments without interruptions, such as Pickup Guides, Air Gaps, etc.)				
Expansion / expansion connectors	Compensation up to 200 m (565 feet) in system length, above 200 m the use of expansion elements is necessary				
Permitted ambient temperature	-30 °C to +55 °C (85 °C in heat-resistant design / PPE + SB)				
Maximum conductor temperature	+85 °C (115 °C in heat-resistant design / PPE + SB, temporarily 125 °C)				
Storage temperature	-30 °C to +40 °C (dry storage; avoid condensation)				
Conductor materials	Depending on type, electrolytic copper, seawater-resistant aluminum with stainless steel contact surfaces, or stainless steel				
Rail insulation	Stabilized hardened PVC (standard material) and PPE + SB (heat-resistant design for interior use)				
Dielectric strength	22.4 kV/mm as defined by DIN 53481				
Leakage current resistance	400 < CTI as defined by IEC 112 / VDE 0303				
Flammability / fire safety	Meets requirements for insulating materials as defined by UL 94 V-0; flame-retardant and self-extinguishing (IEC DIN EN 60895-11-10B), halogen-free PPE-SB				
Local approvals	UL / CSA / GOST-R				
Coloration	Rail insulation in safety warning color RAL 1018 Zinc yellow or RAL 1021 Rape yellow in heat-resistant design				
Relevant Standards					
DIN EN 60664-1, VDE 0110-1:2008-1	Insulation coordination for electrical equipment in low-voltage installations - Part 1: Principles, requirements and testing (IEC 60664-1:2007); German edition EN 60664-1:2007				
DIN EN 60204-1, VDE 0113-1:2007-06	Safety of machines - electrical equipment of machines - Part 1: General requirements (IEC 60204 - 1:2005, modified); German edition EN 60204-1:2006				
DIN EN 60529, VDE 0470-1:2000-09	Protection classes using housings (IP code): (IEC 60529:1989 + A1:1999); German edition EN 60529:1991 A1:2000				
DIN EN 60243-2, VDE 0303-22:2001-10	Electrical dielectric strength of insulating materials - testing procedures - part 2: Additional requirements for testing with direct current (IEC 60243-2:2001); German edition EN 60243-2:2001				
DIN EN 60093, VDE 0303-30:1993-12	Testing procedures for electrical insulation: Specific dielectric strength and specific surface resistance of solid, electrically insulating materials (IEC 60093:1980); German edition HD 429 S1:1983				
DIN EN 60167, VDE 0303-31:1993-12	Testing procedures for electrical insulation: Insulation resistance of solid, insulating materials (IEC 60167:1964); German edition HD 568 S1:1990				
DIN EN 60112, VDE 0303-11:2003-11	Process for determining the test figures and comparison figures for creepage path formation in solid, insulating materials (IEC 60112:2003); German edition EN 60112:2003				

General Instructions

Application Area

This product is intended to supply electric power to mobile machines at the rated current range up to 400 A and voltages up to 690 V / 1000 V. Target applications are crane installations, people movers, and other rail systems, as well as storage/retrieval systems and similar applications with one or more mobile units. The production of arcs / curve elements can be done either at the factory or on-site using appropriate bending tools.

The insulation materials used are resistant to many ingredients used in the industrial environment, depending on concentration and exposure time. All metal parts are available in copper, stainless steel, or seawater-resistant aluminum depending on construction type, and should be evaluated in accordance with the general suitability of these basic materials.

Before using 0812 conductor rails in critical environmental conditions such as galvanizing plants, pickling plants, compost works and locations with high concentrations of chemicals (e.g. solvents, aromatics, benzols, etc.), please contact the factory.

Layout

There are several decisive factors in the selection and layout of conductor rails. One main characteristic is the current load that actually occurs (total current to be expected during operation – not to be confused with the installed power or the resulting maximum current) and the resistance values of the system. Here we look at the longest segment between the power feed and the position of the moving vehicle during start-up. The criterion in question is the resulting voltage drop. Depending on the conductor material and cross section, different losses can result for the same length and current. A conductor rail is properly dimensioned from the point of view of voltage drop when the drop lies within the permitted tolerance range, generally 2-5% and at most 10% including the connection feed cable.

Conductor rails are classified by their rated current. This corresponds to the maximum continuous current for the conductor rail and is based on the standard parameters of 35 °C

ambient temperature and 100% duty cycle (according to IEC ≥ 10 min ON). If the duty cycle or ambient temperature is lower, higher currents can be transmitted. Further information about the layout of conductor rails and corrections to rated current specifications is listed starting on page 22.

Electrical Safety

Insulated SinglePowerLine 0812 conductor rails are designed according to applicable international standards and guidelines, meet today's requirements for the safety of a conductor rail, and have contact protection compliant with DIN EN 60529 (protection class IP 23). They meet the general requirements for classification and evaluation defined in DIN EN 60204 part 32 - electrical requirements for hoisting machines.

Conductor rails and rail components have a high level of safety. With contact protection, direct contact between body parts and electrically conducting parts is prevented (finger protection with DIN VDE and EN /NEMA test fingers / 12 mm foreign bodies). The Current Collectors are also designed finger-safe when engaged in the rails, but in areas where they leave the rails, such as intersections and switch points, they must be additionally protected using power switches, covers, or distance. Installations with voltages over 25 V DC and 60 V AC in publically accessible areas must be secured by covers, installation away from accessible areas, or other suitable means.

Installations in which the insulation characteristics may be reduced by conductive dust or moisture must be installed away from access by people and be marked as high-voltage electrical equipment with warning signs. In areas with high operating voltage (> 690 V) and installations in a highly contaminated environment with conductive dust or moisture, insulators must be used.

The single-pole system can be built with any number of poles and extended in a modular manner. Components for the ground conductor are marked in green or green/yellow and may not be used as phase components. Using installed parts and position coding, it is

impossible to engage the ground Current Collector into a phase pole, or to mix phases. We recommend laying out the PE ("grounding") contact redundantly with dual Current Collectors.¹⁾

Mechanical Safety

Please note that the layout of conductor rails and Current Collectors between fixed and moving system parts must maintain a safety spacing of at least 0.5 m to reduce the possibility of collisions between the moving machine and the rail system – or measures must be taken to prevent this risk. In exposed installation situations, for example over traffic ways, please ask for recommendations.

Use of Conductor Rails

Conductor rails are classified as components or incomplete machines according to the Machine Directive MRL 2006/42/EC. The conductor rails of Program 0812 meet current standards and guidelines for the intended use of the components. For installation into the final product, the specifications valid for this product must be taken into consideration and you must proceed in accordance with the Machine Directive or with the guidelines valid for the place of installation.

Use outdoors

Outdoors, the conductor rail should be protected from environmental influences as much as possible. Use in high humidity and low temperature areas runs the risk of condensation, the formation of frost and ice build-up on the contact surfaces. For installations in this environment, the rails, in particular aluminum rails, must be equipped with an optional rail heater. Our sales department will be glad to assist you with the layout.

Approvals

This conductor rail product line meets the product parameters required for international use for these products and has been developed in accordance with the existing standards and guidelines in the EU and the important industrial markets. In addition to IEC/EN standard compliance, the product line also has local UL/CSA and GOST-R approvals.

¹⁾ Partly specified as standards

System Structure

Components and their use

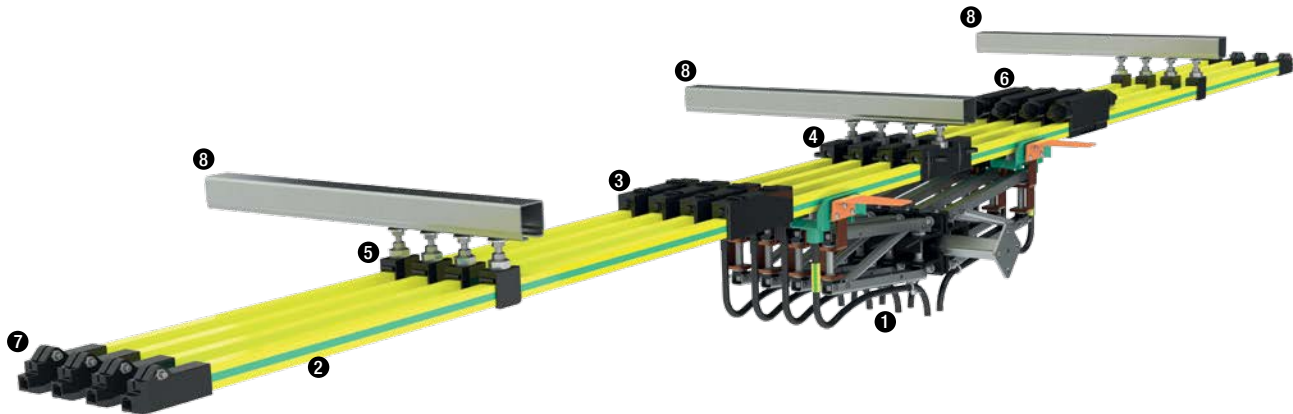

- **1 Current Collector:** Connects to the moving part of the system. Maintains positive contact with the rail as it slides.
Available in different sizes as single or dual Current Collector.
- **2 Conductor Rails:** Stable basic body of conductive material with contact-safe insulated profile.
- **3 Rail Connectors:** Clamping connectors with insulated cap. Can only be removed with a tool (safety requirement).
- **4 Anchor Clamps:** Clamping element for anchoring the system. Forces the rail to expand to either side of the anchor point.
- **5 Hanger Clamps:** Freely rotating and thus self-aligning clip-on holder for quick, safe assembly. Mounting height adjustable.
Allows the rail to slide during thermal expansion.
- **6 Power Feed Connectors:** Used instead of a rail connector. Universal connection of single strands with outer diameters of up to 17 mm.
- **Expansion Units (not shown):** Changing temperature causes the conductor rail system to expand. To compensate for the expansion in systems longer than 200 m or systems with multiple fixed points or curves, expansion joints are used.
- **7 End Caps:** Rail terminator as protection against accidental contact.
- **8 Support Arms**
 - **Pickup Guide (not shown):** For areas in which the collector must be driven in or out of the conductor rail system.
 - **Air Gap (not shown):** For galvanic isolation, for example of segments during maintenance.

System Advantages

- Robust, tried and tested industrial design
- Safe conductor rail with contact protection (finger-safe design)
- Designed to national and international standards
- High availability
- Expandable
- Partial compensation for thermal expansion
- Simple installation
- Optional safety components / functions
- Rails in safety warning color RAL 1018/1021
- CE-compliant design
- Available with any number of poles

System Structure

Insulated Conductor Rails

The standard product line offers electrolytic copper and aluminum as conductor materials. Copper, with its good conductivity, is the ideal conductor, with restrictions in applications in aggressive or corrosive environments. As a budget-priced alternative, aluminum rails with a stainless steel contact surface are also available. Using a special procedure, stainless steel and seawater-resistant aluminum are firmly joined with no gap, combining the advantages of both materials, that is, good conductivity and low wear, without the disadvantages of other aluminum rails available on the market with stainless steel inserts. As another option, for low current and control signals, there are stainless steel rails available as well.

The conductor rails consist of the conductive rail body and the protective insulation in a contact-safe design.

As insulation material, PVC is used in standard applications. For higher ambient temperatures halogen-free PPE+SB is used.

Rated length: 4000 mm

Colour: Safety warning RAL 1018 (PVC) / RAL 1021 (PPE+SB)

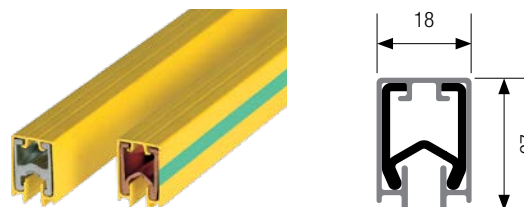

PH = Phase PE = Potential Earth ("grounding")

	Stainless steel	Aluminum (with stainless steel contact surface)		Copper	
Rated current (100% duty cycle)	25 A	200 A	320 A	250 A	400 A
Rated current (60% duty cycle)	32 A	260 A	380 A	320 A	480 A
Cu figure	–	–	–	0.59 kg/m	0.92 kg/m

Part No.	Standard insulation for ambient temperatures up to +55 °C				
PH	081217- 4 x 11	081213- 4 x 11*	081214- 4 x 11*	081215- 4 x 11	081216- 4 x 11*
PE (green color stripes)	081217- 4 x 12	081213- 4 x 12*	081214- 4 x 12*	081215- 4 x 12	081216- 4 x 12*

Part No.	Insulation for ambient temperatures up to +85 °C				
PH	081217- 4 x 21	081213- 4 x 21	081214- 4 x 21	081215- 4 x 21	081216- 4 x 21
PE (green color stripes)	081217- 4 x 22	081213- 4 x 22	081214- 4 x 22	081215- 4 x 22	081216- 4 x 22

Short lengths of 1, 2 and 3 m are available upon request for an additional price for cutting costs

Part No. for semistandard: 0812xx__ length x __ (length = 1 for 1 m, 2 for 2 m, and 3 for 3 m) short lengths upon request – example **1m**: 0812xx-1 x 11

* Standard range

Technical data

Conductor cross section (mm ²)	70	100	120	70	110
DC resistance [Ω/1000m] 20 °C	1.160	0.358	0.267	0.278	0.168
DC resistance [Ω/1000m] 35 °C	1.163	0.377	0.282	0.298	0.178
Impedance [Ω/1000m] 20 °C/50Hz	1.160	0.361	0.297	0.307	0.209
Impedance [Ω/1000m] 30 °C/50Hz	1.163	0.347	0.306	0.321	0.217
Weight [kg]	2.5	1.7	1.8	2.7	4.1
Min. bending radius horizontal	Upon request (depending on outdoor/indoor use, horizontal/vertical orientation and materials)				
Min. bending radius vertical					

Hanger Clamps

Hanger Clamps

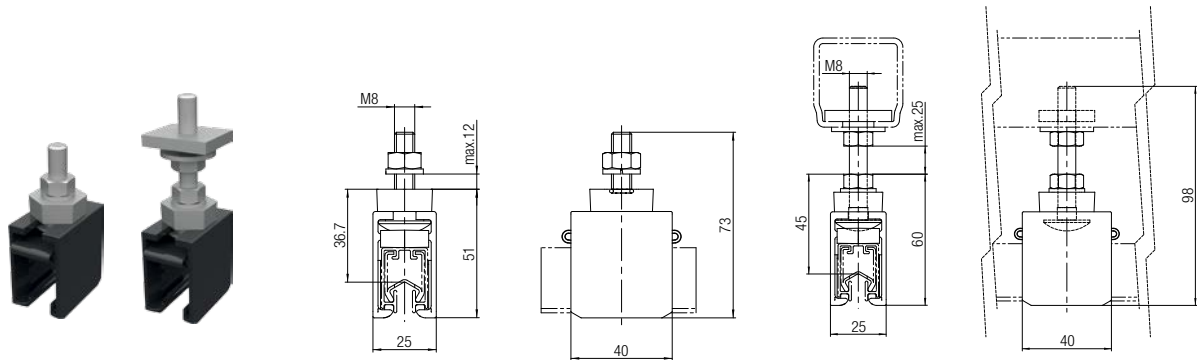

Suspension is carried out using freely swivelling clip-on Hanger Clamps that are self-aligning and permit low-friction slipping in case of thermal expansion. Hanger Clamps are available with hex nuts or square nuts for the mounting of Support Arms / C-rails (see installation accessories).

Note:

- Rated suspension spacing 1.5 m, typically 1.4 to 1.5 m
- Max. suspension spacing 1.5 m
- Minimum spacing from connectors or power feed 400 mm

	Part No.	Weight [kg]
Hanger Clamp galvanized with hex nut	081241-01*	0.050
Hanger Clamp galvanized with square nut	081243-01*	0.095
Hanger Clamp in stainless steel with hex nut	081241-02*	0.050
Hanger Clamp in stainless steel with square nut	081243-02*	0.095

* Standard range

Hanger Clamps with Insulators

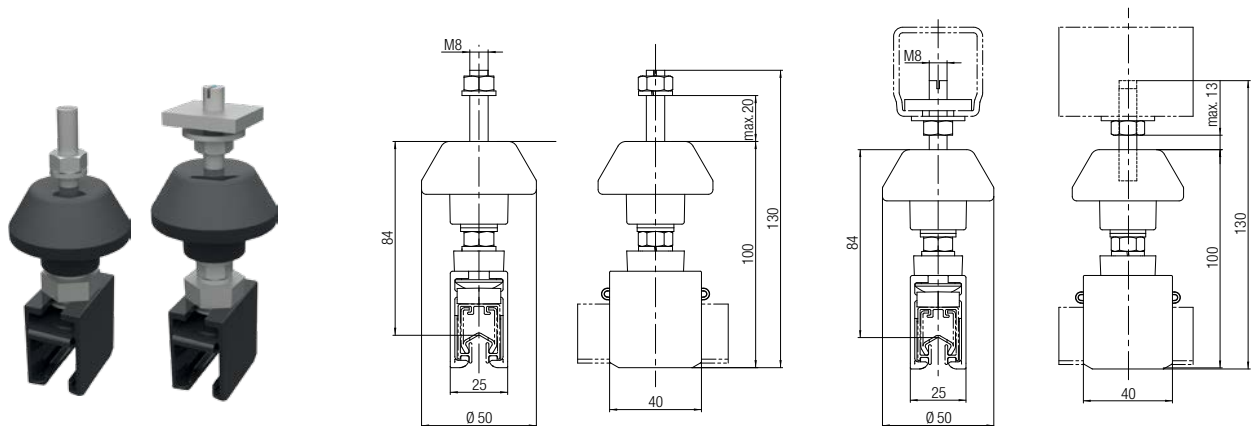

	Part No.	Weight [kg]
Hanger Clamp galvanized with hex nut	081241-11*	0.16
Hanger Clamp galvanized with square nut	081243-11*	0.20
Hanger Clamp in stainless steel with hex nut	081241-12*	0.16
Hanger Clamp in stainless steel with square nut	081243-12*	0.20

* Standard range

Calculation Hint for Hanger Clamps: Quantity $n = \frac{L_{\text{SYSTEM}}}{1.5 \text{ m (hanger distance)}} + 1 + \text{spare part}$

Compact Hanger Clamps and Anchor Clamps

Compact Hanger Clamps

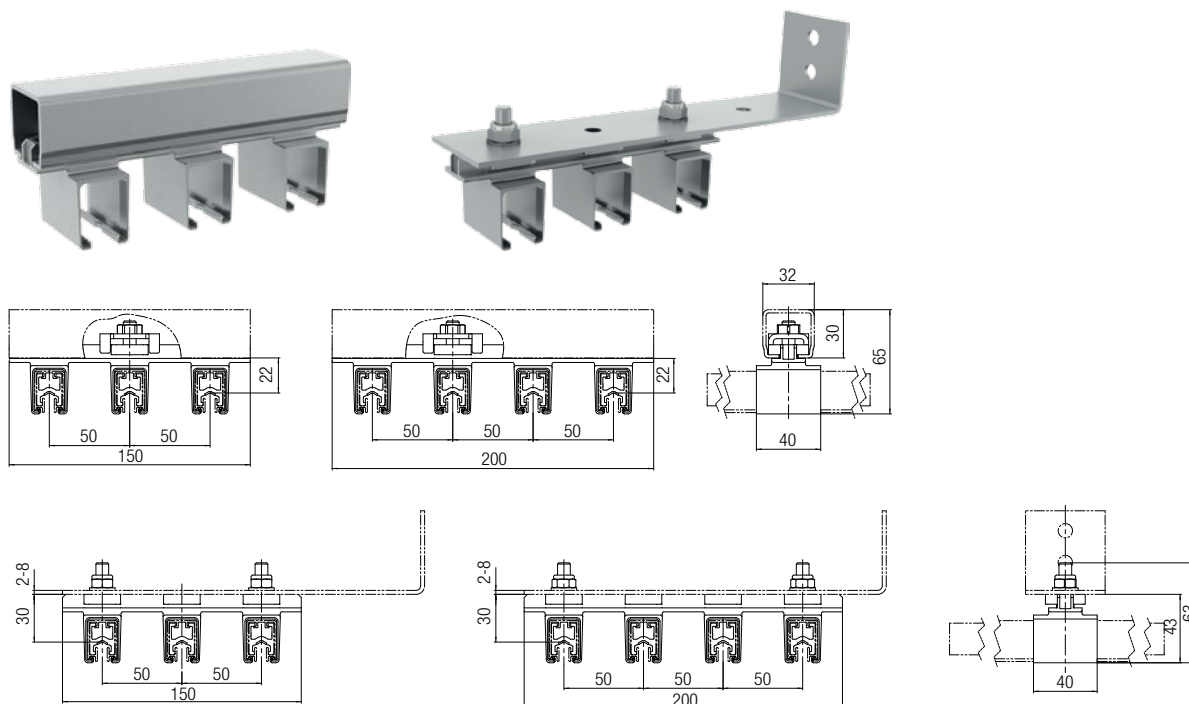

Compact Hanger Clamps for fast assembly of 3 or 4 rails indoors. Available for surface mounting or insertion into Conductix-Wampfler C-rails and mounting brackets in galvanized or stainless steel with 30 mm rated dimensions.

Part No.	Number of poles	Phase spacing [mm]	Variant	Weight [kg]
081246-350	3	50	For C-rails	0.123
081246-351			For extension arms	0.087
081246-450	4		For C-rails	0.138
081246-451			For extension arms	0.102

Note: In contrast to self-aligning rotating single Hanger Clamps, Compact Hanger Clamps and their substructure must be aligned exactly 90° to the rail to ensure free slipping of the rails during expansion. Not suitable for aggressive environments.

Anchor Clamps

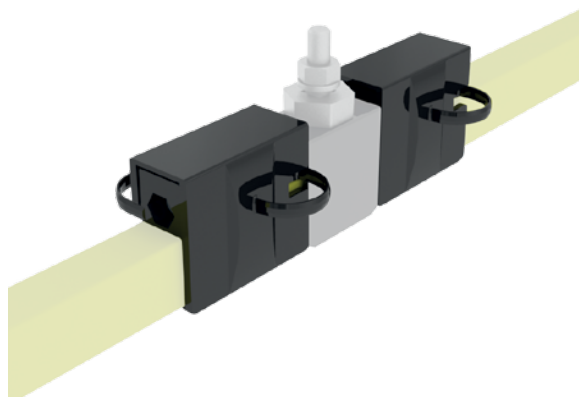

The rails are fixed in one place with Anchor Clamps and can expand freely from that point out. The fixed point is mainly for single feed applications attached close to the power feed or in the center of the conductor rail system. If Expansion Units are installed, please refer location in accordance with diagram 3 on page 15. If multiple fixed points are planned, for example at intersections or curves (natural fixed point), the segment between the fixed points must be decoupled using Expansion Units. Clamps are fastened with a clamping cone on the rail insulator.

Part No.	Type	Weight [kg]
081231-2*	Anchor Clamp	0.050

For each fixed point, order two Anchor Clamps per pole

* Standard range

Rail Connectors and Power Feed Connectors

Rail Connectors (Splice Joints)

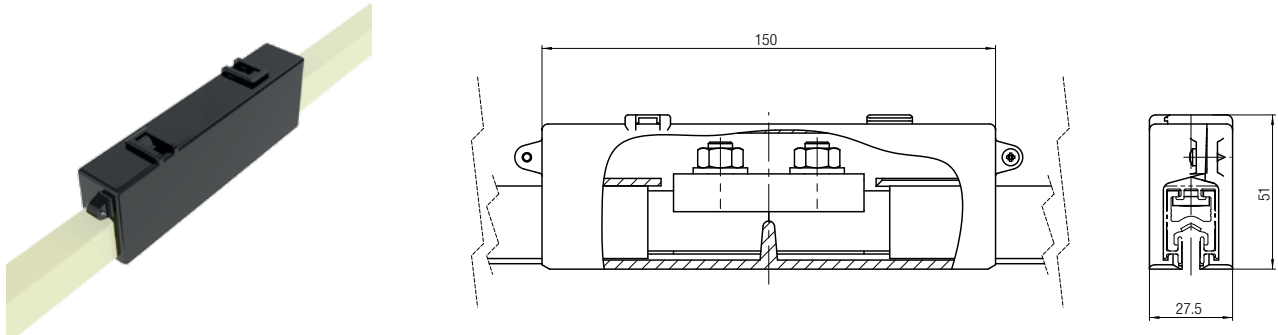

Rails are connected using compact screw connections. The rail connections must have exposed metal on all contact surfaces and be coated with a thin layer of contact grease (Part No. 080021) to protect against corrosion. When mounting clamping screws, use a torque wrench to achieve correct tightening torques.

Part No.	Designation		Weight [kg]
081221-2*	Connectors for aluminum rails	Galvanized	0.130
081221-3*	Connectors for copper rails		0.150
081221-4*	Connectors for aluminum rails	Stainless Steel	0.140
081221-5*	Connectors for copper rails		0.150
081221-6	Connectors for stainless steel rails		0.180
080021*	Contact grease, one 20 g tube (for approx. 200 connection points)		0.035

* Standard range

The standard parts of the connectors are in stainless steel

Power Feed Connectors

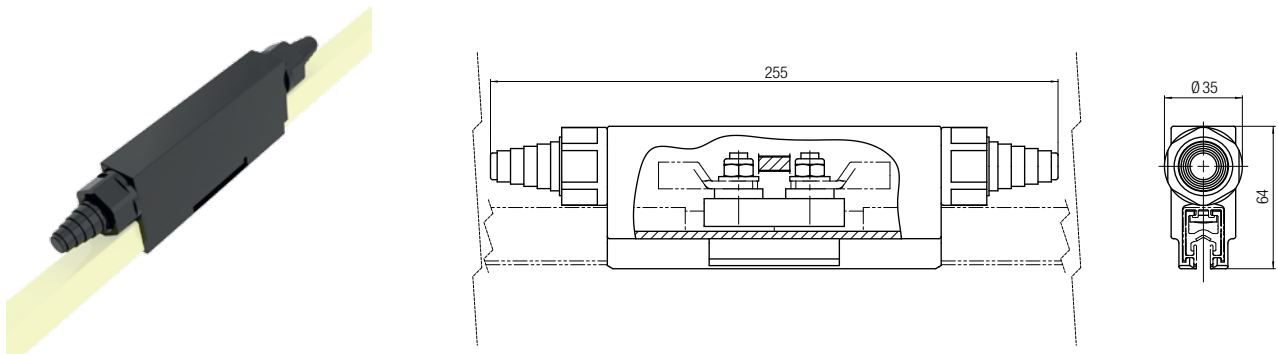

The power feed uses a power connector; these replace the normal Rail Connectors. Electrical connection is provided using projecting bolts and notch-type cable Lugs (cable and cable lugs not included; please order separately).

Note:

- Tightening torque max. 9.75 Nm
- Max. outer cable diameter 17.5 mm
- Use contact grease 080021

Part No.	Designation		Weight [kg]
081251-4*	Power feed connector for aluminum rails	Stainless Steel	0.21
081251-5*	Power feed connector for copper rails		0.22
081251-6	Power feed connector for stainless steel rails		0.25

* Standard range

The standard parts of the connectors are in stainless steel

Notch-type Cable Lugs see page 31

End Caps and Air Gaps

End Caps

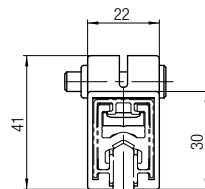
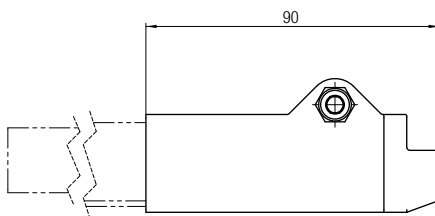
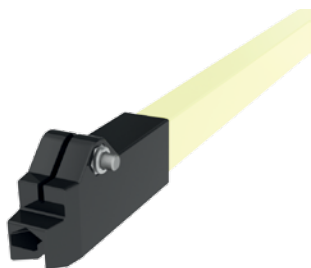

End Caps are used as a rail terminator and contact protection and are fastened to the rails using clamping screws.

Part No.	Designation		Weight [kg]
081271-2*	End Cap	Stainless Steel (DIN parts)	0.040

* Standard range

To use End Caps in combination with accompanying heating / heating conductors: see assembly instructions

Air Gaps

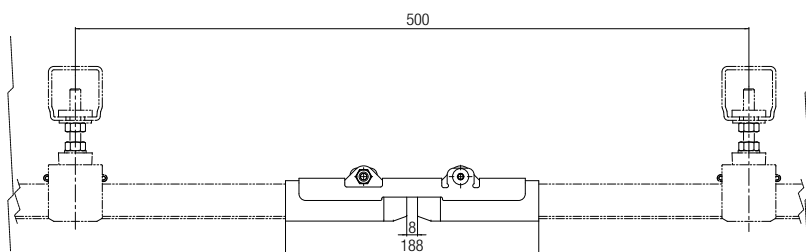

Air Gaps are used for the galvanic isolation of sections, such as maintenance segments that can be supplied with power and turned off separately.

For each separation point, two Air Gaps must be mounted at a suitable distance to avoid power carryover through the Current Collectors.

Part No.	Designation		Weight [kg]
081294-2	Air Gap	Stainless Steel	0.040

Expansion Units

Expansion Units

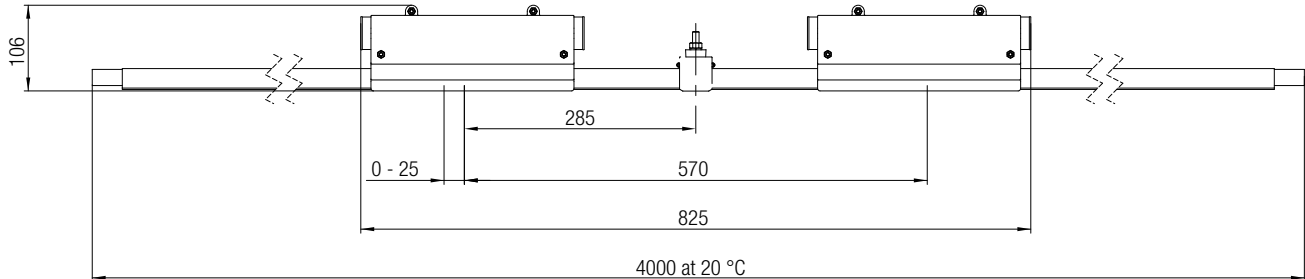

To compensate for changes in length due to temperature for systems > 100 m or segments connected between two fixed points such as Pickup Guides on both ends of the segment, or in curves (natural fixed points), expansion elements are needed to absorb the change in length. The expansion element has two expansion points, each of which can absorb 25 mm of expansion. The expansion elements / expansion unit parts are, like the rails, designed as 4 m standard components.

Note: The middle part between the two expansion segments must be supported using hanger clamps (**not included – order separately**). When using expansion units, the use of dual Current Collectors is recommended.

Rails/ rated current	Part No.				Weight [kg]
	PH (Phase)		PE (Potential Earth)		
	Standard variant	Heat-resistant variant	Standard variant	Heat-resistant variant	
For aluminum rails 200 and 320 A	081261-4 x 2121*	081261-4 x 2221	081261-4 x 2122*	081261-4 x 2222	2.9
For copper rails 250 and 400 A	081261-4 x 2131*	081261-4 x 2231	081261-4 x 2132*	081261-4 x 2232	4.8
For stainless steel rails 25 A	081261-4 x 2141	081261-4 x 2241	081261-4 x 2142	081261-4 x 2242	3.6

Design: Fastening and DIN parts in stainless steel – rated length 4000 mm (13.12 feet). Hanger Clamps in the middle segment not included in scope of delivery – please order separately! Delivery: completely pre-assembled at the factory. Adjustment of the two expansion gaps according to the table on page 15, depending on temperature values.

* Standard Range

Layout notes

Changes in ambient temperature and intrinsic heating cause the conductor rails and the insulation to expand differently. The SinglePowerLine 0812 conductor rail system has a partial thermal expansion system. The difference in thermal expansion between the insulation and the rails is compensated for in each individual rail. For this reason, the insulation profile is specified shorter than the rail and the compensation takes place in the area of the connector caps without influencing the contact guard.

By using self-aligning, rotating Hanger Clamps, the rail line can expand without friction and thus be laid out up to a length of 200 m without additional Expansion Units.

If the power feed is in the middle with a fixed point at the power feed, installations of up to 200 m can be laid out without expansion elements by allowing the segment to expand freely to each side for 100 m from the fixed point.

For installations of greater length, multiple fixed points such as Pickup Guides or curves that also have a fixed position due to a fixed point or mechanical attachment, expansion joints must be used to absorb the changes in length.

Pickup Guides are to be considered as fixing points.

Expansion Units

Expansion Units

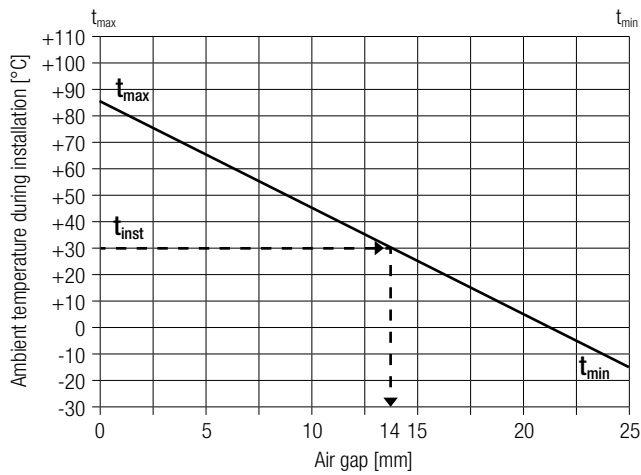

Legend:

- t_{min} lowest temperature that occurs in the application
- t_{max} highest possible working temperature in the application

 1. Draw a connecting line from t_{min} to t_{max} .
 2. Draw the ambient temperature during installation t_{inst} as a horizontal line.
 3. Draw a vertical line down from the point of intersection of these two lines, and read off the air gap to be used during installation.

Example:

Temperature range: from -15 °C to +85 °C
 Ambient temperature during installation: +30 °C
 Air gap: 14 mm per expansion point = 2 x 14 mm for the expansion element

Number of Expansion Units for systems over 100 m in length / 200 m with middle power feed

For rail conductor installations over 200 m in length, Expansion Units must be installed at specific intervals, as shown in Diagram 3. In complicated curves and other special installations, as well as for fixed point arrangements at the end of the system, special intervals must be used. Please contact us.

Number of Expansion Units	1			2			3			4			5			Intermediate length a			
	SS	Al	Cu	SS	Al	Cu	SS	Al	Cu	SS	Al	Cu	SS	Al	Cu	SS	Al	Cu	
Total length of the conductor rail [m]																			
Δt_{tot}	10	400	400	400	600	600	600	800	800	800	1000	1000	1000	1200	1200	1200	200	200	200
	20	400	304	347	600	408	494	800	512	641	1000	616	788	1200	720	935	200	104	147
	30	340	270	298	480	340	396	620	410	494	760	480	592	900	550	690	140	70	98
	40	304	252	274	408	304	348	512	356	422	616	408	496	720	460	570	104	53	74
	50	283	242	258	366	284	316	449	326	374	532	368	432	615	410	490	83	42	58
	60	270	235	249	340	270	298	410	305	347	480	340	396	550	375	445	70	35	49
	70	260	226	242	320	256	284	380	284	326	440	312	366	500	340	410	60	28	42
	80	252	226	236	304	252	272	356	278	308	408	304	344	460	330	380	52	26	36
	90	246	223	232	292	246	264	338	269	295	384	292	328	430	315	360	46	23	32
	100	242	220	229	284	242	258	326	263	287	368	284	316	410	305	345	42	22	29

SS = stainless steel, Al = aluminum, Cu = copper

$$\Delta t_{tot} = \Delta t_U + \Delta t_{sw}$$

Δt_U = Temperature range of the ambient temperature

Δt_{sw} = Temperature increase due to electric current (electrical thermal load)

Recommended values for Δt_{sw} :

10 °C up to 40% duty cycle

20 °C up to 65% duty cycle

30 °C up to 100% duty cycle

For longer systems than those in the table above, use:

$$\frac{L - 200}{a} = \text{number of Expansion Units}$$

Note: Intersection Pickup Guides and curves are fixed points, so these areas must also be taken into consideration when laying out the system.

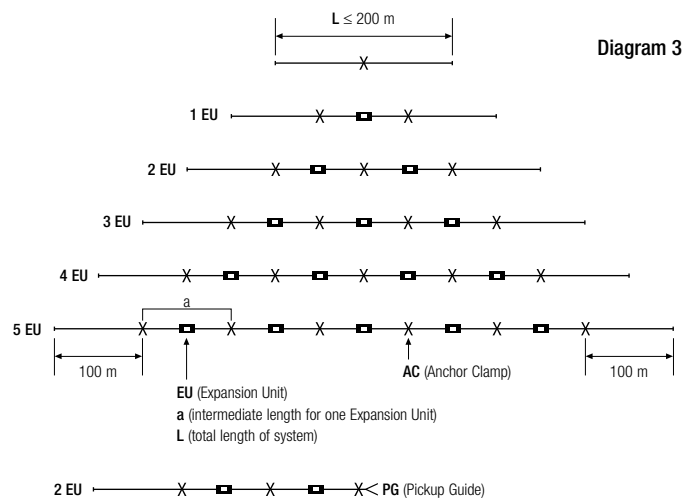

Pickup Guides for Intersections

Only for Current Collectors 081206... / 081208...

For areas in which the collector must be driven in or out of the conductor rail system, Pickup Guides are used in combination with Current Collectors provided for this purpose. The speed for Pickup Guide entry must not exceed 60 m/min and Pickup Guides must be considered wearing parts.

Installation tolerances must be taken into consideration. Simultaneous alignment gaps with maximum tolerances in the X and Y directions are not permitted.

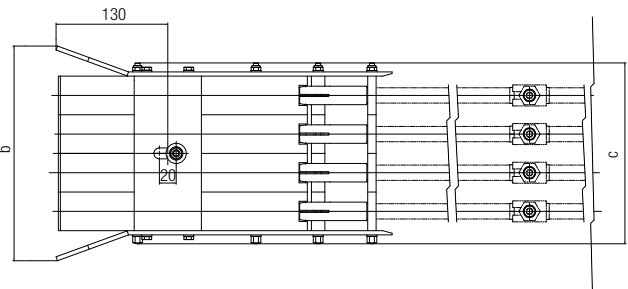
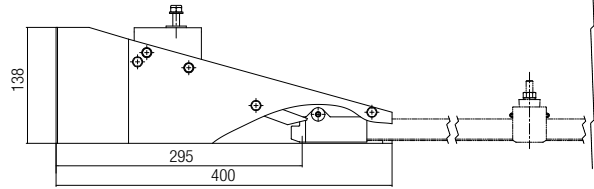
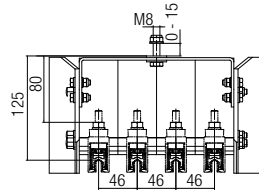
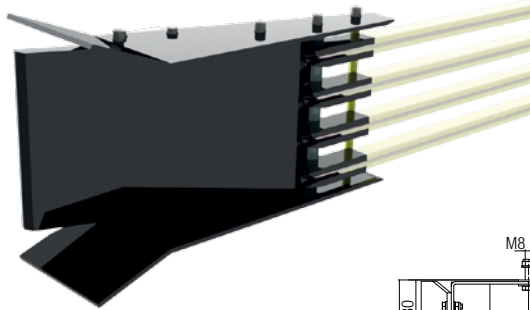

Dimensions [mm]	Number of poles					
	1	2	3	4	5	6
b	120	166	212	258	304	350
c	78	124	170	216	262	308

- The Pickup Guide centers the Current Collector with a maximum lateral and vertical alignment tolerance of ± 25 mm.
- Settings of less than ± 10 mm are recommended.
- In installations with Pickup Guides, a corresponding number of Current Collectors must be available, and mounted in intervals that ensure that just the necessary number of Current Collectors needed for momentary power requirements are in use.

The user must ensure that the Current Collectors between the Pickup Guides are disconnected from power or are protected against accidental contact.

Part No.	Type of fastening elements: stainless steel	Weight [kg]
081281-12	1-pole Pickup Guide	0.850
081281-22	2-pole Pickup Guide	1.200
081281-32	3-pole Pickup Guide	1.550
081281-42	4-pole Pickup Guide	1.900
081281-52	5-pole Pickup Guide	2.100
081281-62	6-pole Pickup Guide	2.300

Installation note

The middle distance between two conductors is 50 mm. This is reduced to 46 mm using the last Hanger Clamps before the Pickup Guide in order to ensure that the Current Collector enters the Pickup Guide precisely. The Pickup Guide is delivered complete with End Caps. The End Caps are pushed onto the rails with a soft-head hammer until they hit the end stops. The clamping screws are then tightened firmly. Keep distance of 750 mm between the Pickup Guide and the first Hanger Clamp.

Hanger Clamp spacing for installations with Pickup Guides

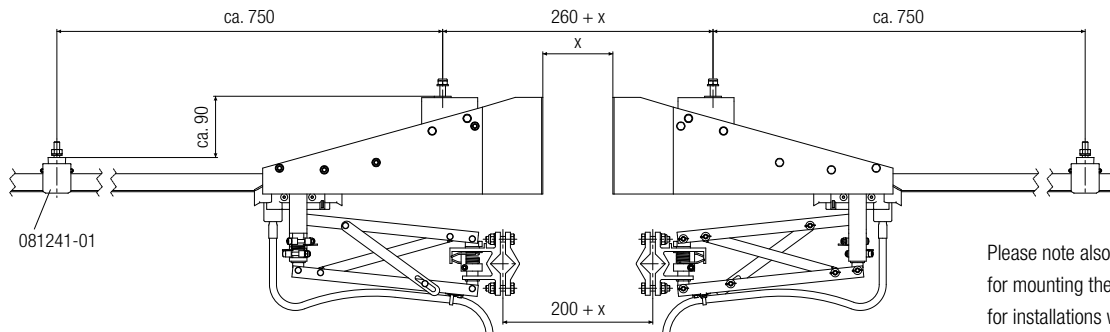

Please note also the instructions for mounting the PE Current Collector for installations with Pickup Guides.

Current Collectors 081209...

Not suitable for Pickup Guides

Types of Construction

For the SinglePowerLine 0812 system there are two basic types of Current Collectors available. In addition to the smaller 081209-xxx variant in plastic, there is also a robust metal parallel arm type available that has proved useful for crane installations. Both types are available as single and dual Current Collectors and are fastened to a Towing Arm with clamps.

Current Collectors (Plastic Arm Type)

Plastic collectors are used in warehouse systems, EOT cranes, and amusement park installations. For installations with one direction of movement, individual Current Collectors **are towed** to reduce wear. By changing the force introduced into the stabilization springs on the Current Collector head, the head is pretensioned and works against the slanted wear. In installations that move in both directions, such as crane runways or transfer cars, this compensation takes place automatically. Here, the variant for **reversible operation** is used.

Single Current Collector set up for reversible operation

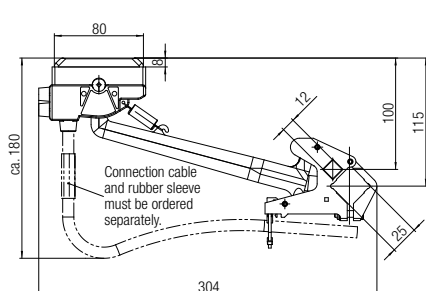

Dual Current Collector set up for reversible operation

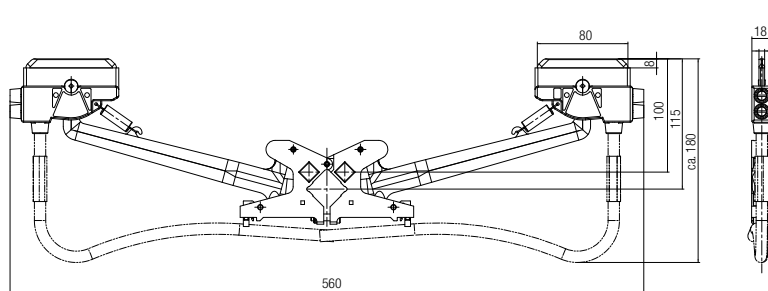

Mounting of Tension Springs

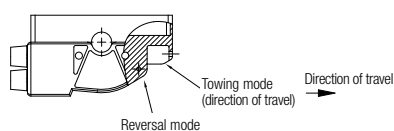

Note: Leave sufficient room in the installation for free movement of the cables. When using horizontal insertion, the weight forces of the Current Collectors must be equipped with compensation springs (**For Towing Arms see page 30, for Accessories and Cables see page 31**).

Technical data

Max. power capacity in straight and curved segments (radius > 1800 mm)	80 A (for aluminum rails in standstill mode at 100% duty cycle: 40 A)	160 A (for aluminum rails in standstill mode at 100% duty cycle: 80 A)
Max. current capacity in curved segments (bending radius from 1000 mm - 1800 mm)	40 A (with special carbon brush 081001-15) (for aluminum rails in standstill mode at 100% duty cycle: 20 A)	
Max. travel speed	600 m/min; higher travel speeds upon request (straight segment without Pickup Guides)	
Pressing force	10 N	
Lateral deviation	max. ± 50 mm	
Working stroke in insertion direction	max. ± 50 mm	
Connection cable	6, 10, or at most 16 mm ² , 1.5 m long, high-flexibility; longer connection cable upon request; order separately (see page 31)	
Distance between the Support arm axis and contact surface of the rail (rated installation dimensions)	115 mm (see system schematic on page 25)	

Variant	Operation: vertical	Single Current Collector		Weight [kg]	Dual Current Collector		Weight [kg]
		80 A			160 A		
		PH (Phase)	PE (Potential Earth)		PH (Phase)	PE (Potential Earth)	
Fastening elements galvanized	Reversible operation	081209-012*	081209-022*	0.300	081209-2 × 012*	081209-2 × 022*	0.520
	Towing operation	081209-013*	081209-023*	0.300	081209-2 × 013*	081209-2 × 023*	0.520
Fastening elements in stainless steel	Reversible operation	081209-112	081209-122	0.300	081209-2 × 112	081209-2 × 122	0.520
	Towing operation	081209-113	081209-123	0.300	081209-2 × 113	081209-2 × 123	0.520

Connection cables not included – order separately from page 31

Note: The connection cables must be highly flexible to ensure free movement of the Current Collectors and be secured with the cable binder on the Current Collector in such a way that no tension or torsion forces are transmitted to the Current Collector head.

* Standard range

Current Collectors

Current Collectors (Parallel Arm Metal Type)

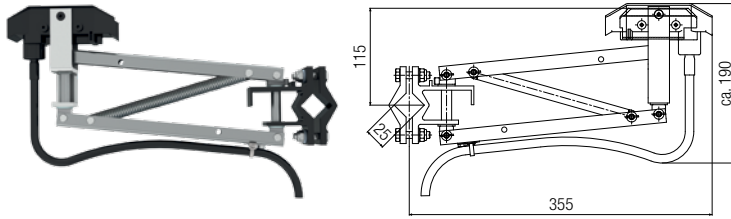

Parallel arm type Current Collectors come in a fully metallic design and are available as single or dual Current Collectors. PE Current Collectors are color-marked with a green Current Collector head and provided with a deflector to prevent insertion into a phase rail.

Horizontal insertion = insertion into the rail from the side
Vertical insertion = insertion into the rail from underneath

Technical data

Max. current capacity in straight and curved segments (bending radius > 1800 mm)	100 A (for aluminum rails in standstill mode at 100% duty cycle: 50 A)
Max. current capacity in curved segments (bending radius from 1000 mm - 1800 mm)	40 A with radius brushes (upon request) (for aluminum rails in standstill mode at 100% duty cycle: 20 A)
Max. travel speed	600 m/min (without rail breaks and curves); higher travel speeds upon request
Pressing force	20 N
Lateral deviation	max. ± 50 mm
Working stroke in insertion direction	max. ± 50 mm
Connection cable	16 mm ² , 1.5 m long, high-flexibility; longer connection cable available upon request; avoid connection cables > 3 m and provide terminal boxes for service and replacement. (SAP CONFIG 3054705)
Distance between Support arm axis and contact surface of the rail (expected dimension)	115 mm

Towing Arms, see page 30

Type	Part No.				Weight [kg]
	PH (Phase)		PE (Potential Earth)		
	Fastening elements galvanized	Fastening elements in stainless steel	Fastening elements galvanized	Fastening elements in stainless steel	
Current Collector 100 A with vertical insertion	081205-01*	081205-11*	081205-02*	081205-12*	1.150
Current Collector 100 A with vertical insertion for intersection ¹⁾ with Pickup Guides	081206-01*	081206-11*	081206-02*	081206-12*	1.260
Current Collector 100 A with horizontal insertion	081207-01	081207-11	081207-02	081207-12	1.185
Current Collector 100 A with horizontal insertion for intersection ¹⁾ with Pickup Guides	081208-01	081208-11	081208-02	081208-12	1.265

¹⁾ Current Collectors for intersections are used if the path of the conductor rail installation is interrupted by branch tracks, crossing beams, etc. These Current Collectors are equipped with a middle centering device and are used with Pickup Guides.

* Standard range

Installation spacing for Current Collectors

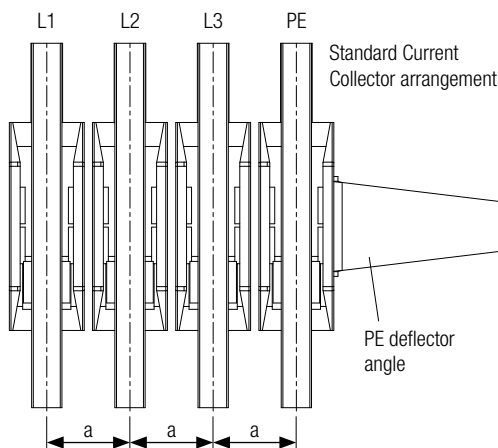

Center spacing a	[mm]
Standard Current Collector arrangement	50
Offset Current Collector arrangement	40
Current Collector arrangement when using Pickup Guides	50

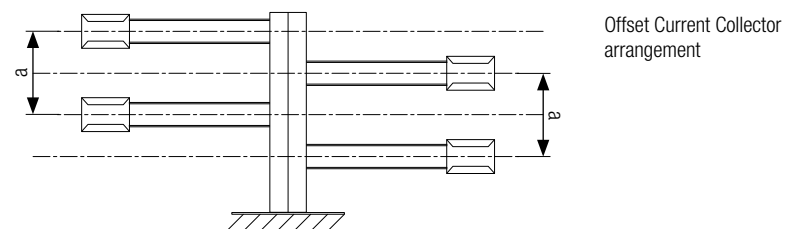

Current Collectors

Dual Current Collectors (Parallel Arm Metal Type)

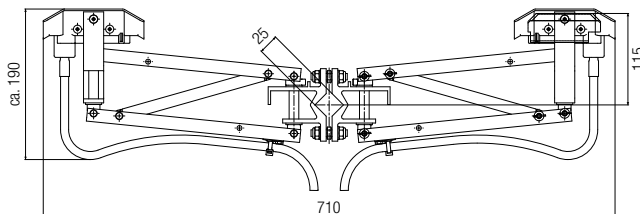
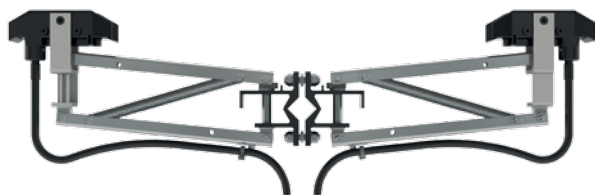

Technical data

Max. current capacity in straight and curved segments (bending radius > 1800 mm)	200 A (for aluminum rails in standstill mode at 100% duty cycle: 100 A)
Max. current capacity in curved segments (bending radius from 1000 mm - 1800 mm)	40 A with radius brushes (upon request) (for aluminum rails in standstill mode at 100% duty cycle: 20 A)
Max. travel speed	600 m/min; higher travel speeds upon request (straight segment without Pickup Guides)
Pressing force	20 N
Lateral deviation	max. ± 50 mm
Working stroke in insertion direction	max. ± 50 mm
Connection line	16 mm ² , 1.5 m long, high-flexibility; longer connection cable available upon request; avoid connection cables > 3 m and provide terminal boxes for service and replacement. (SAP CONFIG 3054707)
Distance between Support arm axis and contact surface of the rail (expected dimension)	115 mm

Towing Arms, see page 30

Type	Part No.				Weight [kg]
	PH (Phase)		PE (Potential Earth)		
	Fastening elements galvanized	Fastening elements in stainless steel	Fastening elements galvanized	Fastening elements in stainless steel	
Current Collector 200 A with vertical insertion	081205-2 × 01*	081205-2 × 11*	081205-2 × 02*	081205-2 × 12*	2.300
Current Collector 200 A with vertical insertion for intersection ¹⁾	081206-2 × 01*	081206-2 × 11*	081206-2 × 02*	081206-2 × 12*	2.520
Current Collector 200 A with horizontal insertion	081207-2 × 01	081207-2 × 11	081207-2 × 02	081207-2 × 12	2.370
Current Collector 200 A with horizontal insertion for intersection ¹⁾	081208-2 × 01	081208-2 × 11	081208-2 × 02	081208-2 × 12	2.530

¹⁾ Current Collectors for intersections are used if the path of the conductor rail installation is interrupted by branch tracks, crossing beams, etc. These Current Collectors are equipped with a middle centering device and are used with Pickup Guides.

* Standard range

Order code for Current Collectors with custom cable length 08120x - 2 x P x L

x = Current Collector type (5,6,7, or 8) L = cable length in whole meters – example for 3 m connection cable: 081206 - 2 x P x 3

Horizontal rail installation with vertical insertion of Current Collectors:

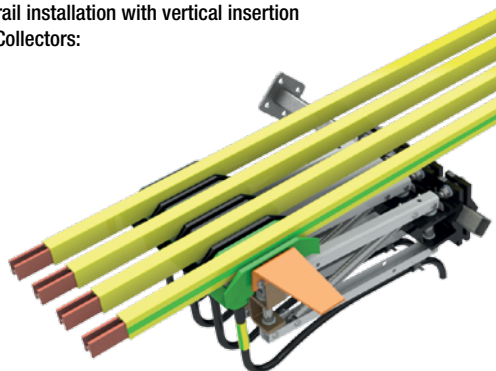

Vertical rail installation with horizontal insertion of Current Collectors:

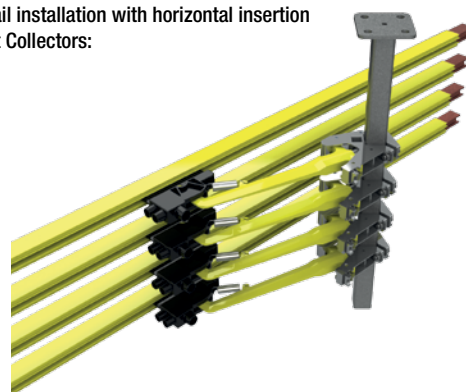

Current Collectors – Installation Instructions

Installation of the PE conductor Current Collector for installations without Pickup Guides

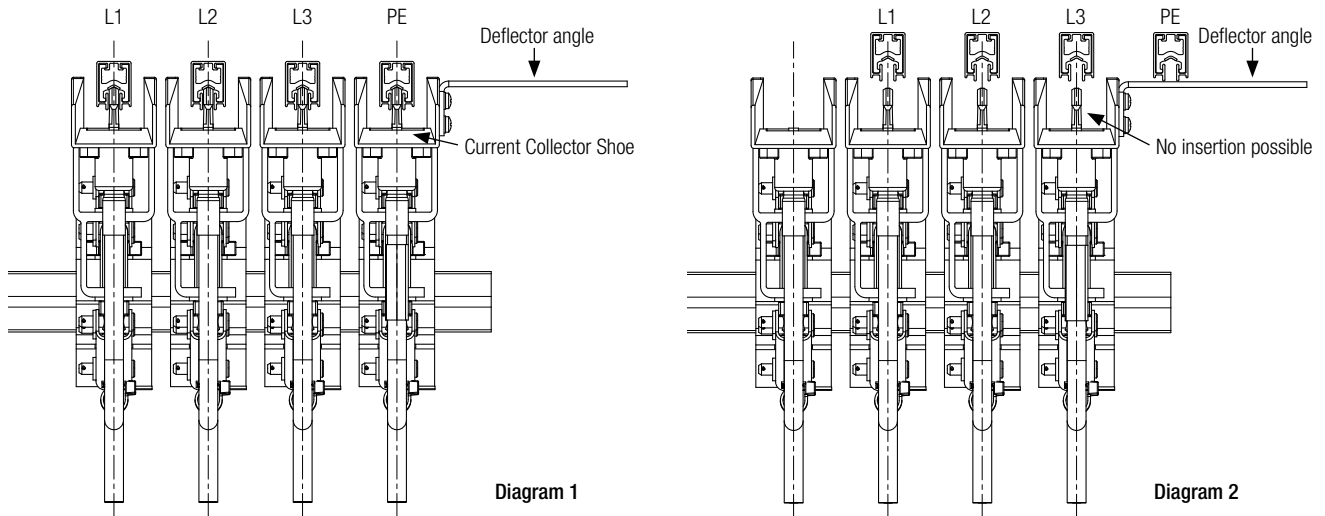

Non-interchangeability of PE (Potential Earth) conductor Current Collectors

To comply with safety standards, Current Collectors for PE rails must be designed in such a way that they are not easily interchangeable with other Current Collectors. When determining the position of the PE conductor, you must take into consideration that the standard PE conductor Current Collector (with deflector angle) can only be mounted on the outside, since the deflector angle is fastened onto the exposed side of the PE conductor Current Collector Shoe. The deflector angle ensures that the PE conductor Current Collector can never come in contact with a phase line (see Diagram 2).

Installation of the PE conductor Current Collector for installations with Pickup Guides

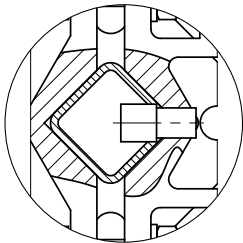

In installations with intersections, it is impossible to move the standard PE conductor Current Collector (with deflector angle) through the Pickup Guide. Thus the PE conductor Current Collector is used for intersections whose holders are equipped with a bolt for the Towing Arm. This fixes the position of the PE conductor Current Collector by being inserted into a hole drilled into the Towing Arm using the Drilling Jig listed below.

This ensures that the PE conductor Current Collector can only be mounted in the place provided for it.

Drilling Jig 08-W100-0206

To comply with regulations and guidelines, installations with Pickup Guides must have a hole drilled into the Towing Arm 020195 using Drilling Jig 08-W100-0206, which is then used to hold the bolt on the PE conductor Current Collector.

Installation note:

The phase Current Collectors needed are lined up on the preassembled Towing Arm 020195 and adjusted to the conductor rails. The next-to-outside phase Current Collector is used as a stop for the Drilling Jig. The Drilling Jig must be attached so that the drill sleeves point outwards – see illustration below. In this position, the mounting spacing is 50 mm.

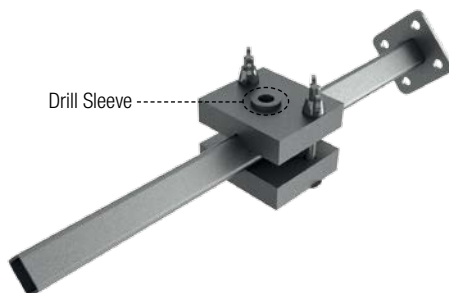

Type	Part No.	Weight [kg]
Drilling Jig	08-W100-0206	0.700



KSR
RENAC

MANITEX
REX 35

FLORES

HANJIN

HANJIN

Dimensioning and Layout of Conductor Rail System

The dimensioning and layout of a conductor rail system is done as follows:

- A: Determine the load current
- B: Select the rail type
- C: Check the voltage drop for the selected rail type
- D: Check of ambient conditions
- E: Select accessories and Current Collectors

A. Determining the load current (total rated current I_{NG})

To determine the total expected load current, individual currents of the highest draw consumers that can operate simultaneously are added up. If the entire installed power is summed, the rail capacity will be over-specified. To avoid overdimensioning, the individual currents are evaluated for simultaneity. To optimize the system, it is always wise to consider individual consumers that cannot be operated simultaneously (e.g. a crane's slewing gear can only be operated when the crane trolley is stopped), and then only the consumer (the slewing gear or the trolley) with the higher current consumption is used.

If multiple units are installed on a single track, for example three cranes on one crane track, the probability of simultaneous operation in the same load should be used to calculate the current. In practice, the following simple table has proved useful in calculating the total rated current I_{NG} for multiple consumers:

Selection help for standard EOT crane applications

Number of cranes	I_N of the most powerful motor of all the cranes I_N^*	I_N of the second most powerful motor of all the cranes I_N^*	I_N of the third most powerful motor of all the cranes I_N^*	I_N of the fourth most powerful motor of all the cranes I_N^*
1	×	×		
2	×	×	×	
3	×	×	×	
4	×	×	×	×
5	×	×	×	×
According to work with 2 cranes	×	×	×	×

* = For dual drives, use $2 \cdot I_N$

B. Rail current capacity depends on duty cycle and ambient temperature

The specified rated currents for the conductor rail are based on the definitions in European standards and are relative to an ambient temperature of 35 °C and a duty cycle (DC) of 100%. If the duty cycle is shorter, such as might be the case for a crane with finite movement, the rail can conduct higher current than the rated current.

Adjusting the rail rated current for shorter duty cycles

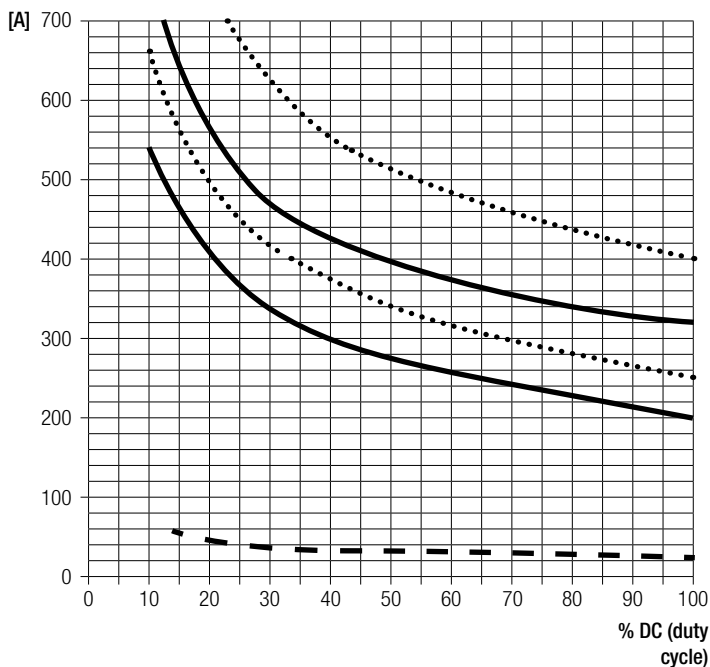

The load current of the conductor rail can be increased for shorter duty cycles. **Note:** When comparing the rated currents of rails from different manufacturers, always take into consideration the reference ambient temperature and the duty cycle! Consumptions with 100% duty cycle such as lighting, air conditioning or magnetic grippers must be taken into consideration. 100% DC $\hat{=}$ $t \geq 10$ min. (according to EN standards)

- 400 A Copper rails
- 320 A Aluminum rails
- 250 A Copper rails
- 200 A Aluminum rails
- 25 A Stainless Steel rails

Dimensioning and Layout

If the ambient temperatures differ from the standard value of 35 °C, the loads must be adjusted. At lower temperatures, the heat release (convection) is better and the rail can handle higher current loads. At higher temperatures, the release of thermal energy to the surrounding air is slower and the load must therefore be reduced.

Use with voltages under 230 V must be tested in each specific case. The minimum current should be 1A. The corresponding values f_A are taken from the following table:

Ambient temperature			35 °C	40 °C	45 °C	50 °C	55 °C	60 °C	65 °C	70 °C	75 °C	80 °C	85 °C
Standard insulation	Stainless steel rails	f_A	1.0	0.97	0.94	0.91	0.88						
	Aluminum rails		1.0	0.92	0.81	0.76	0.68						
	Copper rails		1.0	0.93	0.87	0.82	0.78						
Heat-resistant insulation	Stainless steel rails	f_A	1.0				1.0	0.97	0.94	0.91	0.88	0.85	0.83
	Aluminum rails						1.0	0.92	0.81	0.76	0.68	0.63	0.59
	Copper rails						1.0	0.93	0.87	0.82	0.78	0.74	0.72

$$I_{SCHL\ G\ zul} = I_{SCHL\ G\ zul\ 35\ ^\circ C} \cdot f_A \quad I_{SCHL} = \text{rated current of the conductor rail for the specific ambient temperature}$$

C. Calculating the voltage drop

After selecting the rail type based on the calculated total current depending on duty cycle and ambient temperature, the voltage drop must be checked. The calculated voltage drop must be under the value specified by the customer. Typical values here are 2-5%, or 10% in exceptional cases. If the voltage drop is too high, the voltage might be too low for all the drives to start.

The following formulas are used for the calculation:

For direct current	$\Delta U_{35\ ^\circ C} = 2 \cdot I \cdot I_G \cdot R$	[V]	$\Delta U_{35\ ^\circ C}$ = voltage drop at 35 °C	[V]
			I_G = total current	[A]
For alternating current	$\Delta U_{35\ ^\circ C} = 2 \cdot I \cdot I_G \cdot Z$	[V]	R = resistance of the conductor rail	[Ω/m]
			Z = impedance of the conductor rail	[Ω/m]
For three-phase power	$\Delta U_{35\ ^\circ C} = \sqrt{3} \cdot I \cdot I_G \cdot Z$	[V]	I = feed length	[m] ¹⁾
			L = conductor rail length	[m]

Note: I_G here is the portion of the load current "drawn" during start-up.

¹⁾ see feed variants

This consists of the basic load, like lighting and air conditioners, and the start-up currents of the drives I_A .

For start-up current, the following applies:	Three-phase asynchronous drive in direct start	$I_A = I_G \times 5$ to 6 (up to max. 21 kW permitted)	I_G = total current
	Slip ring rotor motor	$I_A = I_G \times 2$ to 3	I_A = Total current consumption when starting
	Frequency converter	$I_A = I_G \times 1.2$ to 1.5	

The length I is the distance between the power feed and end position of the conductor rail segment on which the consumer is located when starting.

If the average ambient temperature is significantly over 35 °C, the voltage drop must be calculated using the following formulas:

$\Delta U \sigma = \frac{\Delta U_{35\ ^\circ C}}{f_V}$	[V]	$\Delta U \sigma$ = voltage drop at higher ambient temperature than 35 °C	[V]
$\Delta U \sigma \% = \frac{\Delta U \sigma}{U_N} \cdot 100$	[%]	$\Delta U \sigma \%$ = voltage drop at higher ambient temperature than 35 °C	[%]
		U_N = rated voltage [V]	
		f_V = reduction factor	

To calculate the value f_V , the working temperature must first be calculated.

$\sigma_{AT} = \sigma_{UT} + \Delta \sigma_{SW} = \sigma_{UT} + 30$	[°C]	σ_{AT} = working temperature [°C]
		σ_{UT} = ambient temperature [°C]
		$\Delta \sigma_{SW}$ = temperature increase due to current heating [°C] (use a constant +30 °C)

The value f_V is based on the working temperature and the conductor rail selected and should be taken from the table "Correction factors for the voltage drop ΔU for different ambient temperatures" on page 24.

Dimensioning and Layout

Correction factors for the voltage drop ΔU at different ambient temperatures

Ambient temperature		35 °C	40 °C	45 °C	50 °C	55 °C	60 °C	65 °C	70 °C	75 °C	80 °C	85 °C
Working temperature / conductor temperature		65 °C	70 °C	75 °C	80 °C	85 °C	90 °C	95 °C	100 °C	105 °C	110 °C	115 °C
Standard insulation	Aluminum rails 200 A	f _v	0.916	0.904	0.891	0.879	0.868					
	Aluminum rails 320 A		0.921	0.909	0.897	0.886	0.875					
	Copper rails 250 A		0.912	0.899	0.887	0.874	0.862					
	Copper rails 400 A		0.927	0.916	0.905	0.894	0.883					
	Stainless steel rails 25 A		0.993	0.991	0.990	0.989	0.988					
Heat-resistant insulation	Aluminum rails 200 A	f _v					0.868	0.856	0.845	0.834	0.824	0.813
	Aluminum rails 320 A						0.875	0.864	0.853	0.843	0.833	0.822
	Copper rails 250 A						0.862	0.850	0.838	0.827	0.816	0.805
	Copper rails 400 A						0.883	0.873	0.863	0.853	0.843	0.833
	Stainless steel rails 25 A						0.988	0.986	0.986	0.985	0.984	0.982

If the voltage drop is too high, then either the number of power feeds must be increased or a larger conductor rail must be selected. Additional power feeds are usually a better technical and commercial alternative than larger conductor rails or costly copper rails.

Working temperature: permanent rail temperature occurring at rated current (ambient temperature + electrical thermal heating)

Max. working temperature: short-term (t < 30 sec) 125 °C (in heat-resistant variant)

Possible power feed locations: The power feed arrangement must be appropriate for the specific case, since the voltage drop is calculated with the feed length "l" that falls between the power feed and the end of the conductor rail. The following power feed options are normally used:

End power feed

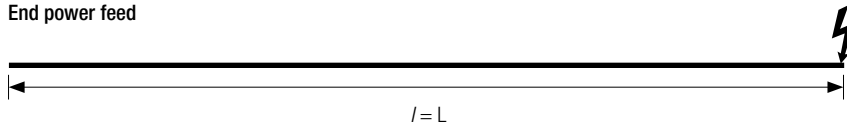

Middle power feed

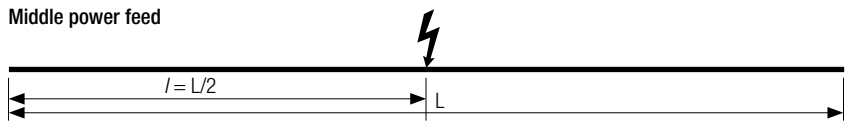

Power feed on both sides

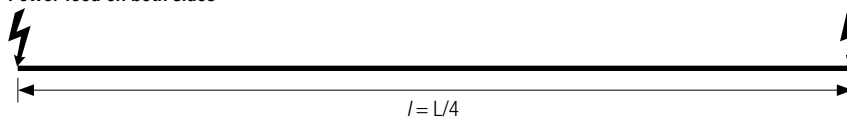

L/6 power feed

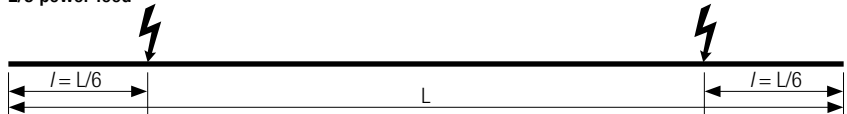

L/10 power feed

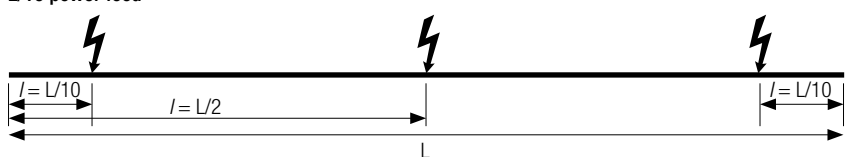

L/14 power feed

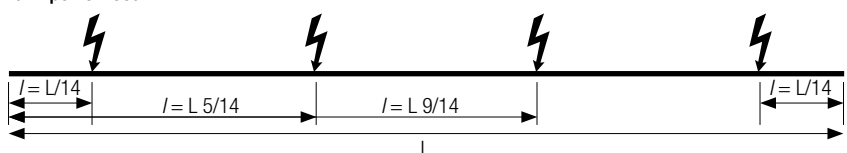

- l = L With an end power feed
- l = L/2 With a middle power feed
- l = L/4 For power feeds at both ends
- l = L/6 For two power feeds each L/6 from the ends
- l = L/10 For a power feed in the middle and L/10 from each end
- l = L/14 For four power feed points

L = length of the conductor rail [m]

System Layout

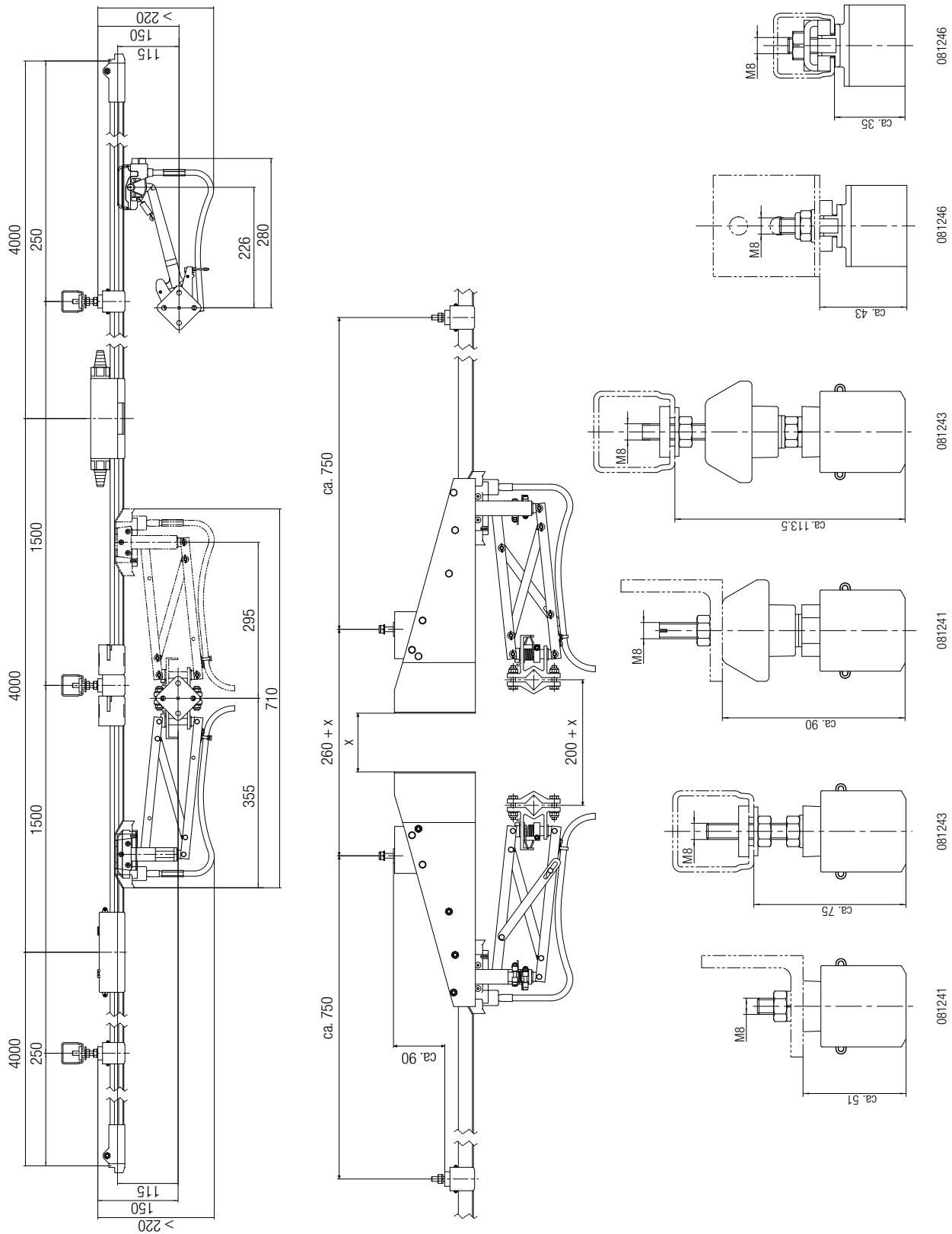

Note: Used outdoors, the conductor rail system must be protected from direct weather exposure as much as possible, for example by installing it under a beam and covering the Current Collector (to protect it from snow and ice). Outdoors, insertion of the Current Collector from below is generally preferable to lateral insertion. Also, the use of insulated holders is recommended for outdoor installations. If there is any risk of formation of frost or ice, specify heating conductors in the rail to de-ice the rail and prevent rail damage due to sparking effects on frozen rails.

System Layout

Layout Schematic and Component Overview

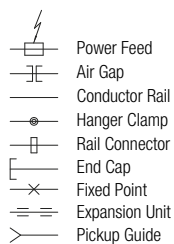
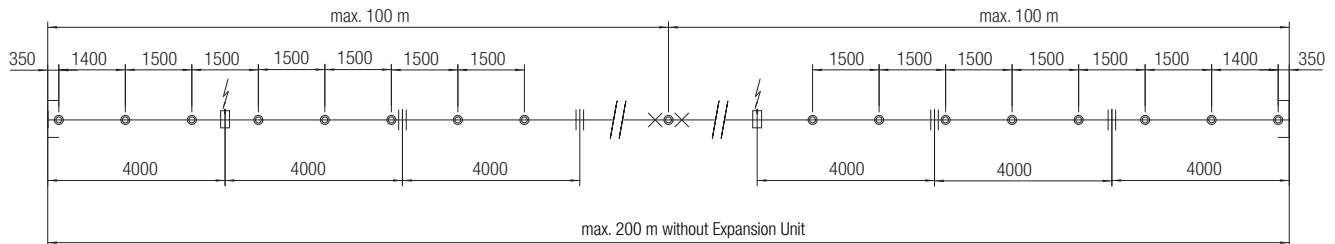

Middle distance between two conductors	Standard Current Collector arrangement	Offset Current Collector arrangement	Current Collector arrangement for installations with multi-poled Pickup Guides*
Minimum distance a [mm]	50	40	50

* See mounting instructions for Pickup Guides. Minimum distance between Hanger Clamps, Joints, Pickup Guides, Air Gaps, etc. is 250 mm! Minimum distance for Power Feeds is 350 mm.

Example Material Overview / Example Order

Here is a typical crane conductor rail system that is 52 m in total length, with 4 poles, 320 A, with all accessories, Current Collectors and Support Arms. The required Bill of Materials is listed below. The order quantity should be increased by an assembly reserve for the parts marked with an (x).

Part Description	Part No.	Quantity Needed
Conductor Rail "Phase" 4 m long	0812-4 × 11	39
Conductor Rail "PE" 4 m long	0812-4 × 12	13
Hanger Clamp (x)	081243-01	152
Anchor Clamp	081231-1	8
Rail Connector (x)	081221-2	52
Power Feed	081251-2	4
Notch-type Cable Lug 16 mm ² (x)	080051-16	4
End Cap (x)	081271-1	8
Current Collector "Phase"	081205-01	3
Current Collector "PE"	081205-02	1 (Recommendation: 2 units or dual Current Collector)
Support Arm	020195-400	1
Support Arm	020185-0500	38
Girder Clip	020180-08	76
Mounting Comb	081045	1
Conductix-Wampfler Contact Grease (x)	080021	1
Copper Graphite Shoe (replacement part) (x)	081001-11	4

Note:

To avoid strand breakage due to external force on the Current Collector, the connection cable should be fine-stranded and highly flexible. The transition to the customer-provided fixed cabling should be directly behind the Current Collector in a terminal box provided by the customer. Long connection cables to Current Collectors should be avoided to reduce maintenance problems.

Mounting Accessories

Support Arms 30 x 32 x 2 mm – also suitable for Compact Hanger Clamps

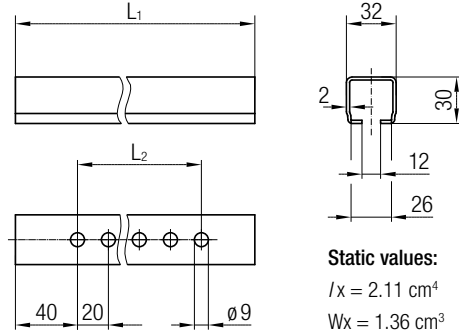

Static values:
 $I_x = 2.11 \text{ cm}^4$
 $W_x = 1.36 \text{ cm}^3$

Part No.	L ₁ [mm]	L ₂ [mm]	Material	Weight [kg]
020185-0250	250	200	Galvanized steel	0.390
020185-0315	315	260		0.500
020185-0400	400	340		0.625
020185-0500	500	340		0.780
020185-0630*	630	340		0.980

* Standard range

Permissible load for Support Arms 30 x 32 x 2 mm

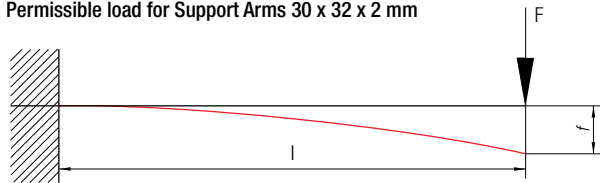

	l [m]							
	0.25	0.32	0.40	0.50	0.63	0.80	1.00	1.25
F [daN]*	76.0	59.5	47.5	38.0	30.0	24.0	19.0	15.2
f [cm]	0.08	0.13	0.20	0.32	0.50	0.80	1.25	2.23

* Calculated with $\sigma = 140 \text{ N/mm}^2$ voltage $f =$ associated max. deflection

Support Arms 40 x 40 x 2.5 mm – not suitable for Compact Hanger Clamps

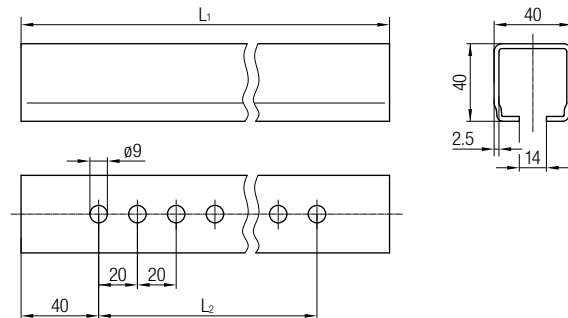

Part No.	L ₁ [mm]	L ₂ [mm]	Material	Weight [kg]
020186-0250	250	200	Galvanized steel	0.625
020186-0315	315	260		0.785
020186-0400*	400	340		1.000
020186-0500	500	340		1.250
020186-0630*	630	340		1.575
020186-0800	800	340		2.000

* Standard range

Permissible load for Support Arms 40 x 40 mm

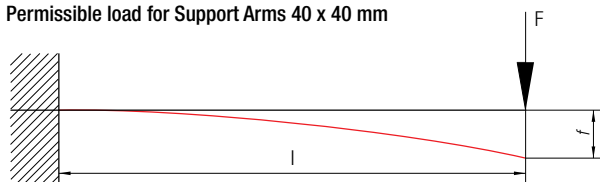

	l [m]							
	0.25	0.32	0.40	0.50	0.63	0.80	1.00	1.25
F [daN]*	164.5	128.5	103.0	82.5	65.5	51.3	41.0	32.9
f [cm]	0.06	0.10	0.16	0.25	0.40	0.63	1.07	1.68

* Calculated with $\sigma = 140 \text{ N/mm}^2$ voltage $f =$ associated max. deflection

Mounting Accessories

Holder for Support Arms 30 × 30 × 2 for screw mounting with 2-holed connector plate

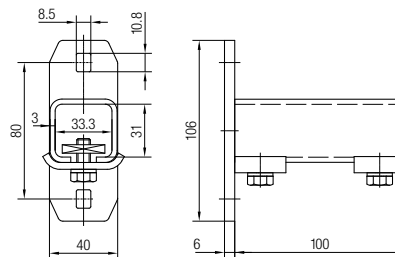

Part No.	Description	Suitable for Support Arm	Weight [kg]
020280	Galvanized steel	020185, 020275	0.700

Holder for Support Arms 30 × 30 × 2

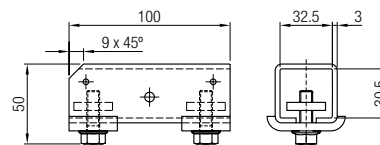

Part No.	Description	Suitable for Support Arm	Weight [kg]
020285	Unplated steel with galvanized hardware	020185, 020275	0.420

Holder for Support Arms 40 × 40 × 2.5 for screw mounting with 2-holed connector plate

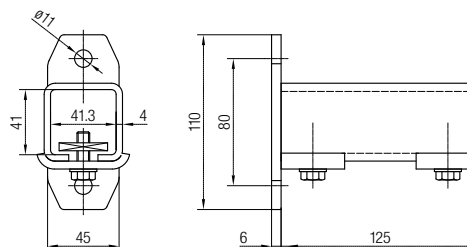

Part No.	Description	Suitable for Support Arm	Weight [kg]
020282	Galvanized steel	020186, 020276	1.000

Holder for Support Arms 40 × 40 × 2.5

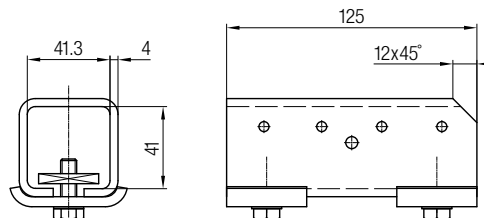

Part No.	Description	Suitable for Support Arm	Weight [kg]
020286	Unplated steel with galvanized hardware	020186, 020276	0.730

Mounting Accessories

Girder Clips, clamping thickness 4 - 20 mm

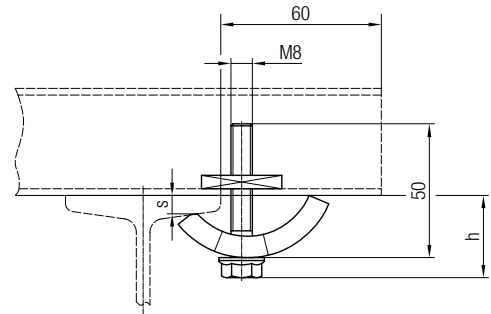

Part No.	Description	Weight [kg]
020180-08*	Galvanized steel	0.150
020480-08	Stainless steel (V4A)	0.150

* Standard range

Clamping thickness s [mm]	4	6	8	10	12	16	20
Installation height h [mm]	31	32	33	34	35	37	40

Girder Clips, clamping thickness 18 - 36 mm

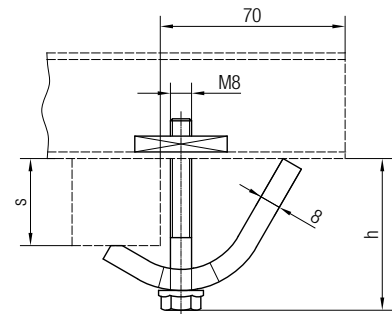

Part No.	Description	Weight [kg]
020180-08 × 36	Galvanized steel	0.220
020480-08 × 36	Stainless steel (V4A)	0.220

Clamping thickness s [mm]	18-20	20-24	24-28	28-32	32-36
Installation height h [mm]	42-44	44-48	48-52	52-56	56-60

Girder Clips, non-twistable, clamping thickness 6 - 25 mm

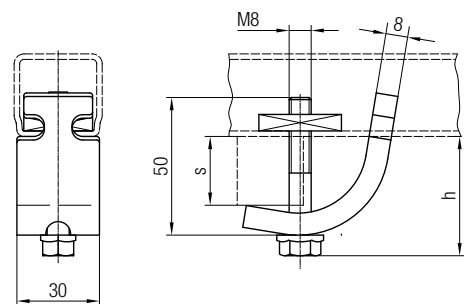
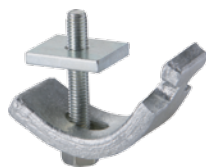

Part No.	Description	Weight [kg]
020181-08	Galvanized steel	0.190

Clamping thickness s [mm]	6-25
Installation height h [mm]	32-40

Mounting Accessories

Towing Arms

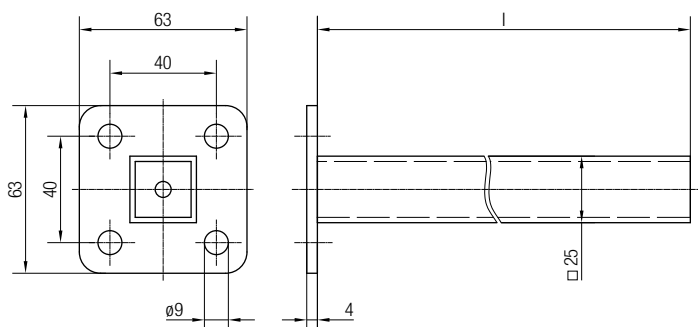

Part No.	Description	l [mm]	Weight [kg]
020195-630	Galvanized steel	630	1.000
020495-630	Stainless steel (V4A)	630	1.000

* Standard range

Length adaptation on site

End Caps

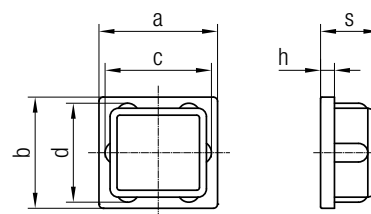

Part No.	For Support Arm	Description	a [mm]	b [mm]	c [mm]	d [mm]	s [mm]	h [mm]	Weight [kg]
020662-30	020185	Plastic	30	32	27	29	18	5	0.005
020662-40	020186		40	40	35	35	21	5	0.004

Insulators

Insulators for indoor applications with high contamination and/or applications outdoors, up to 1000 V rated voltage

Creepage distance 62 mm
Leakage current resistance KC 575 V (CTI)
Cantilever strength > 350 daN
Ambient temperature -30 °C to +85 °C

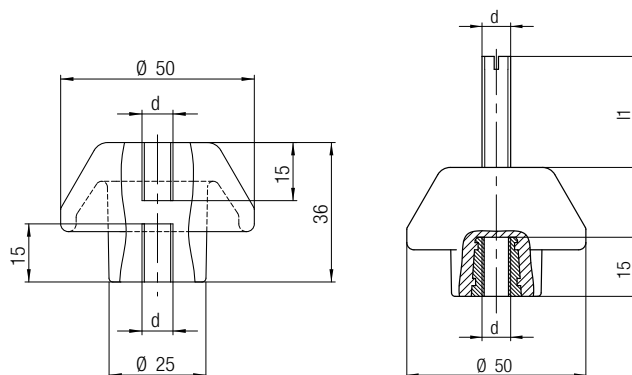

Part No.	Hardware	d	l ₁ [mm]	Weight [kg]
080401-08 × 08	Inner threading on both ends	M8 / M8	-	0.09
080403-830 × 08	Threaded bolts, galvanized	M8 / M8	30	0.98
080403-830 × 08	Threaded bolts, stainless steel	M8 / M8	30	0.98

Mounting Accessories

Notch-type Cable Lug for Power Feed Line

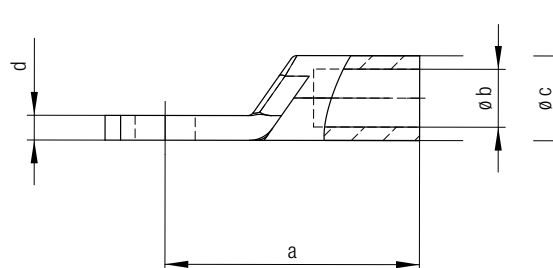

Part No.	Cross section [mm ²]	a [mm]	b [mm]	c [mm]	d [mm]	Weight [kg/1000]
080051-06*	6	23.5	3.5	6.6	1.5	6.000
080051-10*	10	26.8	4.5	7.0	1.5	7.000
080051-16*	16	32.0	5.5	8.5	2.2	11.000
080051-25*	25	32.5	7.0	10.0	2.6	14.000
080051-35*	35	34.0	8.5	12.0	3.5	20.000
080051-50*	50	40.0	10.0	14.0	3.9	32.000
080051-70*	70	47.0	12.0	16.6	4.6	51.000
080051-95*	95	51.0	13.5	18.0	4.6	60.000

Material: Copper, tin-plated Order lot size 10 pcs. per size * Standard range

Connector Cable for Current Collector Head 081209

Cross section [mm ²]	Part No.		Length* [m]	Cable diameter [mm]	Rated current [A]	Weight [kg]
	PH (Phase)	PE (Potential Earth)				
6	081209-1.5 × 06 × 81	081209-1.5 × 06 × 92	1.5	6	54	0.086
10	081209-1.5 × 10 × 91	081209-1.5 × 10 × 92	1.5	7	73	0.147
16	081209-1.5 × 16 × 81	081209-1.5 × 16 × 82	1.5	10	98	0.234

* Custom lengths and bulk cables by request

Note: The connection cables are stressed by movement during operation and must be inspected along with the carbon collector shoes at regular intervals, then replaced after every five replacements of the carbon collector shoes. We recommend connecting the cables to a junction box, then installing fixed cabling from the junction box on.

Spring Assembly (lateral insertion) for Current Collector Head 081209

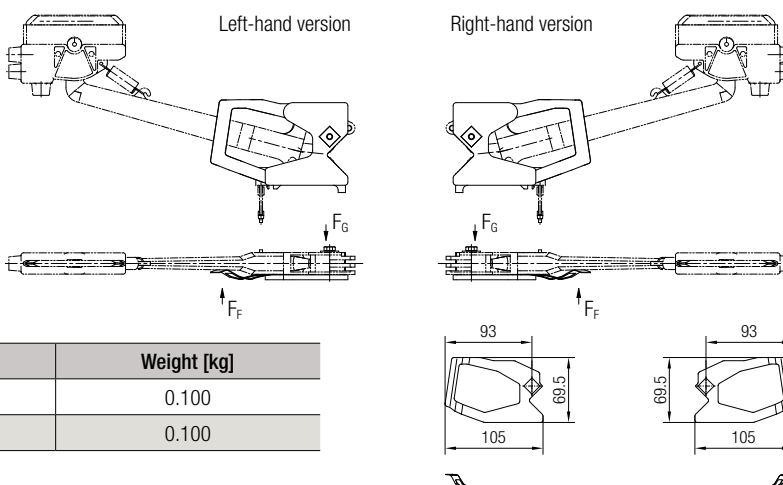

Spring assembly 081209	Part No.	Weight [kg]
Right-hand version	08-F030-0100	0.100
Left-hand version	08-F030-0101	0.100

Tools and Assembly Accessories

Mounting Comb 081045

For setting the rail holder spacing while mounting the Support Arms

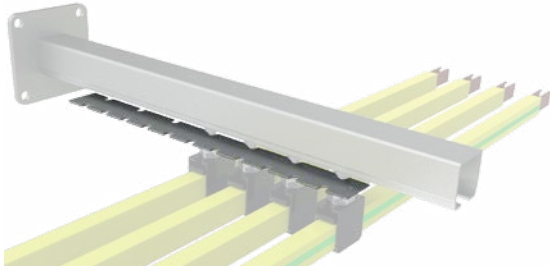

Part No.	Description	Weight [kg]
081045*	Mounting Comb	0.190

* Standard range

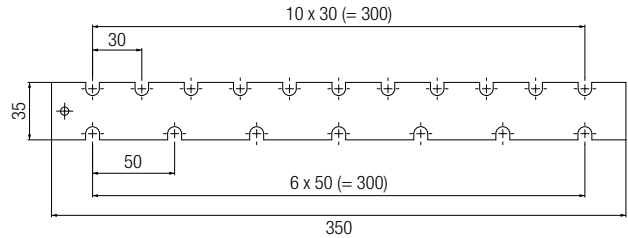

Bending Device 081010



Part No.	Description	Weight [kg]
081010*	Bending Device	20.000
081011*	Spring band package	5.000

* Standard range

Horizontal and vertical curves for all conductor rails in the Program 812 can be bent using the Bending Device 081010 (see also Technical Information Sheet TI0812-0019-E). For bending curves, the spring band package is also included and must be inserted into the profile form.

When the Bending Device is ordered, a complete set of spring bands (inserts) and a bending manual are included.

Contact Grease for Connection Points



Part No.	Type	Weight [kg]
080021*	Contact Grease	0.030

* Standard range

Application: Use contact grease to avoid corrosion at contact points. A thin film is applied with finger or brush to the faces of the conductor rail and the clamping area of the connectors.

One tube will last for about 200 connection points.

Replacement Parts

Complete Current Collector Head for Current Collector 081209

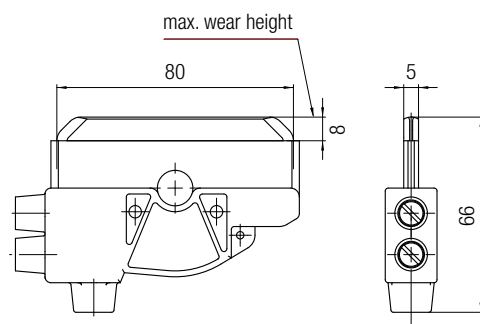
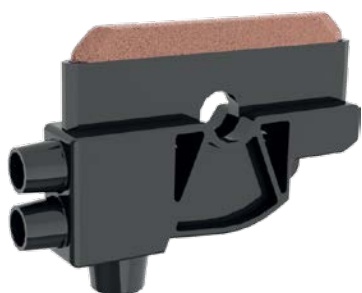

Description	Part No.		Weight [kg]
	PH (Phase)	PE (Potential Earth)	
Copper Graphite Shoe 812, 80 A, reversible operation	081001-12*	081001-22*	0.090
Copper Graphite Shoe 812, 80 A, towing operation	081001-32*	081001-42*	0.090

Note: The carbon brush and plastic insulation should always be replaced together.

* Standard range

Stabilization Springs for Current Collector Head 081209

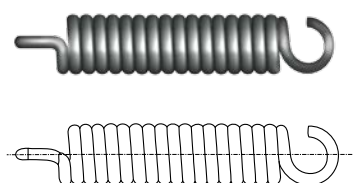

Type	For Current Collectors	Operating type	Part No.
Stabilization spring	081209-	012	RZ-081 GI
		022	
		112	
		122	
Stabilization spring	081209-	013	RZ-0561
		023	
		113	
		123	

Replacement Copper Graphite Shoes with Insulators for Current Collector Head 081205... / 081206... / 081207... / 081208...

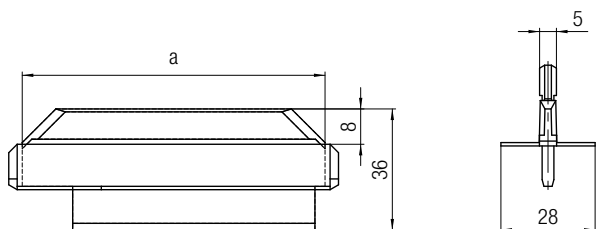
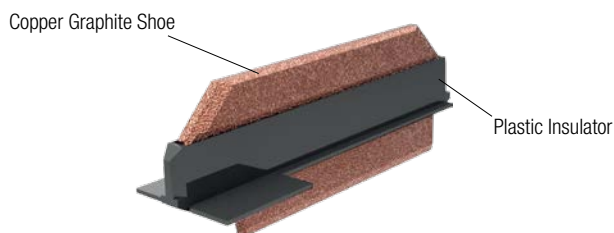

The copper graphite shoe is protected by a plastic insulator, so that accidental contact with live parts of the engaged Current Collector is not possible.

Smallest bending radius for 100 A copper graphite shoe $R = 1800$ mm – smallest bending radius for 40 A copper graphite shoe $R = 1000$ mm

Part No.	Type	Amperes [A]	a [mm]	Weight [kg]
081001-11*	Copper graphite shoe	100	90	0.098
08-K154-0090	Copper graphite shoe for outdoor applications	100	90	0.098
081001-15	Copper graphite shoe	40	63	0.058

Installation note: When replacing the Copper graphite shoe, it is not necessary to remove the collector head because the shoe is designed as a plug-in contact (not a screw contact). Insulator is included.

* Standard range

Replacement Parts

Replacement Parts for Current Collectors

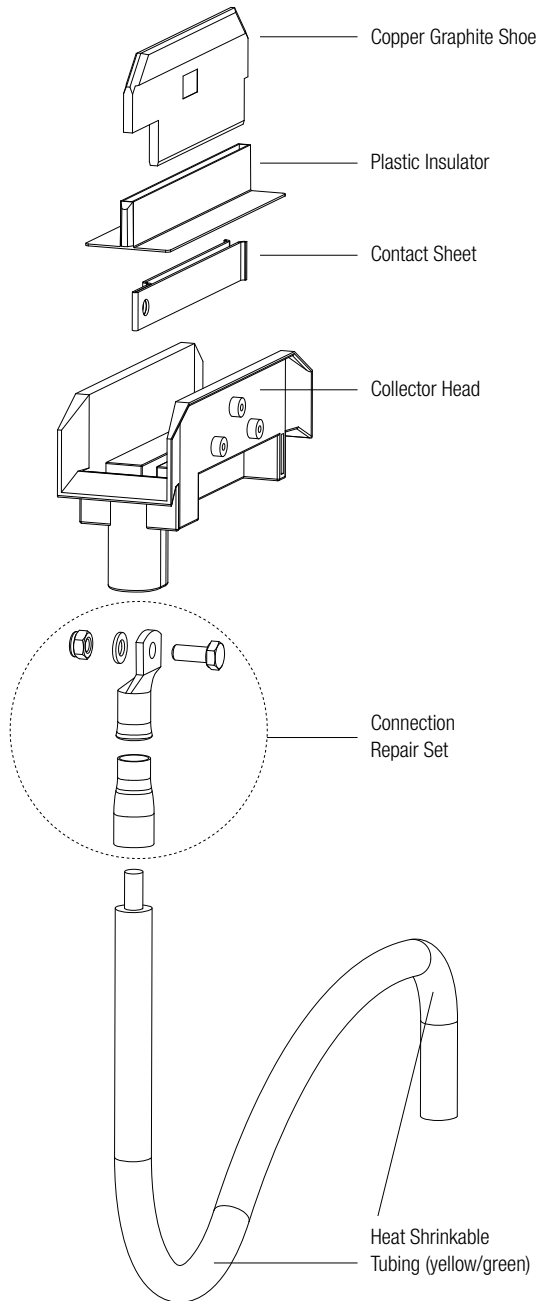

Part No.	Type	Weight [kg]
08-A150-0001-2*	Collector Shoe PE	0.1
08-A150-0001-1*	Collector Shoe PH	0.1
08-K154-0397*	Connection Repair Set, including: 1 × Contact Sheet (1846) 1 × Tubular Cable Lug (24120) 1 × Heat Shrinkable Tubing black, 55 mm (24121) 10 × Heat Shrinkable Tubing yellow/green, 50 mm (24139) 1 × Hexagonal Screw DIN933 M8 x 20 (1120) 1 × Lock-nut DIN985-M08-A4 (580) 1 × Washer DIN125-A8, 4-A4 (685)	0.6
	Connecting Cable	
	Connecting Cable (pre-assembled) – on request	

* Standard range

Other Products from Conductix-Wampfler

Series 812 Conductor Bar from Conductix-Wampfler represents only one product line from the broad spectrum of Conductix-Wampfler components for the transfer of energy, data, gases, and fluids. The solutions we deliver for your applications are based on your specific requirements. In many cases, a combination of several different Conductix-Wampfler products are needed to fill the application. You can count on all of Conductix-Wampfler's business units for hands-on engineering support - coupled with the perfect solution to meet your energy management and control needs.



Motor driven cable reels

Motor driven reels by Conductix-Wampfler are the perfect solution for managing long lengths of heavy cable and hoses in very demanding industrial applications. Monospiral, level wind, and random wind spools.



Slip ring assemblies

Whenever powered machinery needs to rotate 360°, field proven slip ring assemblies by Conductix-Wampfler can flawlessly transfer energy and data. Here, everything revolves around flexibility and reliability.



Energy guiding chains

The "Jack of all Trades" when it comes to managing energy and data cables and air and fluid hoses. A wide range of energy guiding chains are available for many industrial applications.



Inductive Power Transfer IPT®

The contact-less system for transferring energy and data. For all tasks that depend on high speeds and absolute resistance to wear.



Welded Cap Conductor Rail

Our patented Welded Cap Rail gives you the conductivity and light weight of aluminum plus the wearability of stainless steel.



Cable Festoon systems

It's hard to imagine Conductix-Wampfler cable trolleys not being used in virtually every industrial application. They are reliable and robust and available in an enormous variety of sizes and models.



Push Button Pendants

Our ergonomic pendants are ideally suited for industrial control applications. They are available in a wide range of configurations for overhead cranes and other machinery.



Radio remote controls

Safe, secure, and reliable radios use the latest in microprocessor technology. Available in several models for overhead crane control and other types of machinery.



Workstation equipment

Complete with tool transporters, reels, or an entire air and electric supply system. Workstation equipment provides safety and flexibility for difficult tasks.



Air hoists and balancers

ENDO Air hoists accurately place delicate loads and continuously vary the speed for precise positioning. They run cool in continuous operations.



Bumpers

Conductix-Wampfler offers a complete range of bumpers for the auto industry, cranes, and heavy machinery. These include rubber, rubber/metal, and cellular types.



Spring balancers and retractors

ENDO spring balancers by Conductix-Wampfler are rugged, reliable high-precision positioning devices that reduce operator fatigue and assist with accurate tool placement.

www.conductix.us

USA / LATIN AMERICA

10102 F Street
Omaha, NE 68127

Customer Support

Phone +1-800-521-4888

Fax +1-800-780-8329

Phone +1-402-339-9300

Fax +1-402-339-9627

info.us@conductix.com

latinamerica@conductix.com

CANADA

175 Blvd JF Kennedy
St. Jerome, QC J7Y 4B5

Customer Support

Phone +1-800-667-2487

Fax +1-800-442-9817

Phone +1-450-565-9900

Fax +1-450-432-6985

info.ca@conductix.com

MÉXICO

Calle Treviño 983-C
Zona Centro
Apodaca, NL México 66600

Customer Support

Phone (+52 81) 1090 9519

(+52 81) 1090 9025

(+52 81) 1090 9013

Fax (+52 81) 1090 9014

info.mx@conductix.com

BRAZIL

Rua Luiz Pionti, LT 05, QD.
L - Vila Progresso
Itu, São Paulo, Brasil
CEP: 13.313-534

Customer Support

Phone (+55 11) 4813 7330

Fax (+55 11) 4813 7330

info.br@conductix.com

Contact us for our Global Sales Offices

