

Multipole Conductor Rail

831 Series Multiline

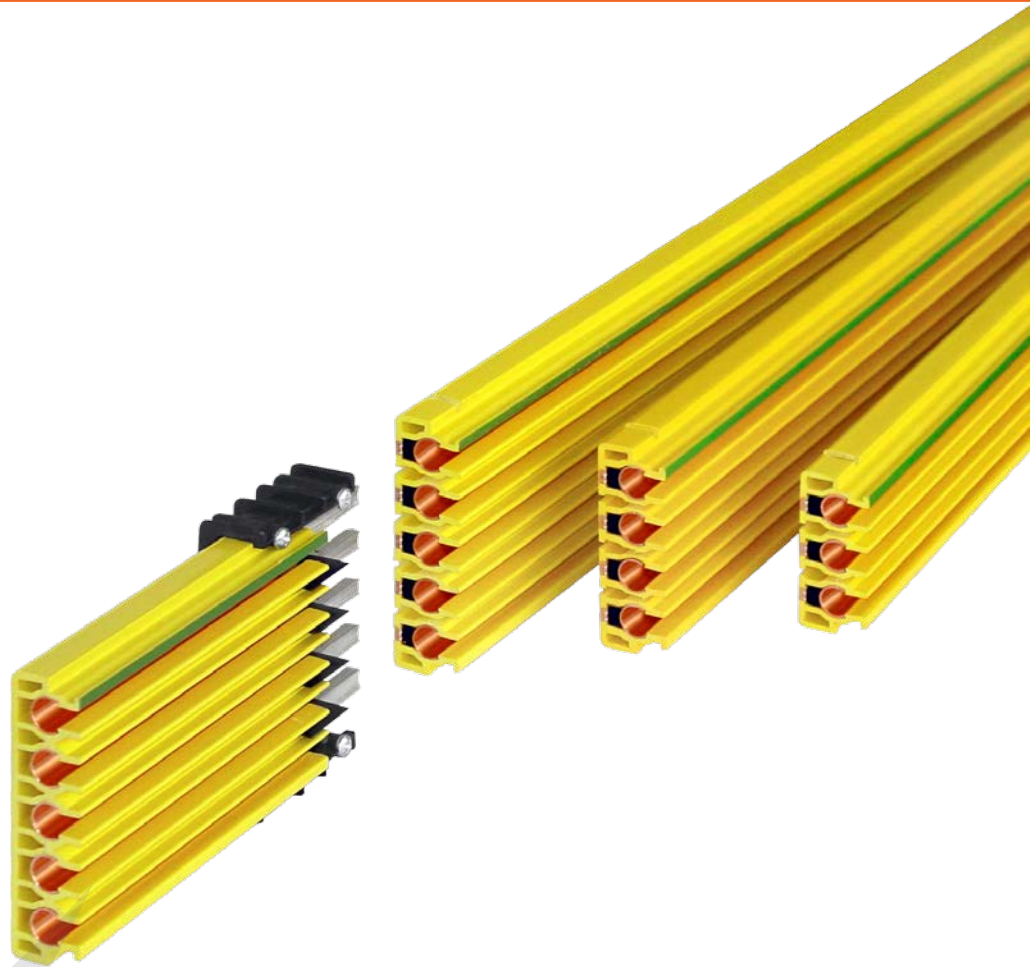

CONDUCTIX
wampfler

© DELACHAUX GROUP

Contents

Description / Technical Data

Description	4
Technical Data	5

Conductor Rails

Rails complete with pre-mounted Connector	6
Power Feeds	7
Hanger Clamps	9
Anchor Clamps	10
End Caps	11
Air Gap Insulating Sections	12
Pick-up Guides for Transfer Points	13
Expansion Element	14

Current Collectors with Accessories

Collector Support Brackets for current collector	15
Support Spring Plates	15
Connection Cable	15
Current Collector Units	18
Double Current Collector Units	19

Wearing and Spare Parts

Rail Connectors	23
Collector Shoes	23
Stabilizing Springs for Current Collector Head	23

Mounting / Accessories

Support Arm	24
Girder Clip	24
Weld-on Bracket for Support Arm	24

Others

Arrangement Examples	25
Program Overview	25
General Hints	25

Description

Conductix-Wampfler Multipole Conductor Rail Program 0831

The Conductix-Wampfler multipole conductor rail program 0831 is protected against direct contact and designed as a flat profile. This system is recommended for high storage bays, cranes, transport trolleys and special machinery. The Conductix-Wampfler multipole conductor rail can be used for energy and data transmission on indoor and weather protected outdoor applications with straight track layouts.

- 3, 4 and 5-poles
- 10 - 125A (100% Duty cycle)
- protected against direct contact
- little space consumption
- installation vertical and horizontal
- quick installation due to connector plug-in system and universal steel clamp fasteners

CONDUCTOR RAILS

The conductor rail poles are enclosed in high-quality plastic profiles in 3, 4 and 5 pole type. There are different versions for a current load from 10 up to 125A nominal current. The phase spacing of the multipole profiles is 18 mm. With a combination of different multipole profiles every number of multipole conductor systems is possible.

The standard length is 4000 mm, shorter lengths are available. It is possible to combine different conductor rail types within the compact profiles. Datametal conductor rails will be used for a reliable data transmission. In special cases please ask for assistance.

SUPPORT / HANGER CLAMPS

The conductor rail segments have to be fastened at least at 2 points. The support distance is max. 1000 mm. The plastic hanger clamps can be mounted on customers supporting beams or runway profiles as well as on Conductix-Wampfler support arms. With universal steel clamp fasteners they can be mounted on the beam flanges. The multipole conductor rail will be snapped into the hanger clamps which are designed as sliding hanger clamps.

SUPPORT / ANCHOR CLAMPS

To control the expansion an anchor clamp will be installed, which holds the multipole conductor rail in position in the hanger clamp, due to an additional screw. The anchor clamp will preferably be located in the middle of an installation.

POWER FEED

Power feeds are available as end feed or in-line feed up to 35 mm² cross section, as well as flat centre feed up to 35 mm² cross section. In-line feeds can be installed at each rail joint. The power feeds are rail segments with a length of 1000 mm, except for the end feeds.

EXPANSION JOINTS

Expansion joints are used as expansion compensators in systems which are exceeding a total length of 200 m (see page 12/13).

In case you need expansion joints please ask for assistance.

RAIL CONNECTORS

The rail segments are connected with a special connector plug-in system. The rail connector is already included at the end of each rail segment.

PICK-UP GUIDES FOR TRANSFER POINTS

A reduced travel speed will increase the lifetime. A limit of max. 85 m/min is recommended.

INSTALLATION

For detailed information please refer to our installation instruction (MV0831-0006-E).

Current Collectors

The current collector unit with or without terminal box is installed on the mobile power consumer. It consists of fully insulated current collectors which are moveable in all directions. The earth collector is marked green/yellow and not interchangeable with a phase collector. Collector shoes can be checked without disassembling and can be replaced quick and easily. In special cases please ask for assistance.

	Current Collectors		Current Collector Units				
			with Terminal Box	single without Terminal Box		double with Terminal Box	
max. Current at 100% Duty Cycle [A]	55	80	55	55	80	68	110
Order No.	083102-... (page 14)	083106-... (page 15)	083103-... (page 19)	083103-... (page 17)	083107-... (page 18)	083104-... (page 21)	083104-... (page 20)
... also for Pick-up Guides ... for Transfer Points	yes	yes	no	yes	yes	no	no

Technical Data

Conductix-Wampfler Multipole Conductor Rail Program 0831

Conductor Rail	Galvanized steel	Copper			Data-metal
		083112	083115	083116	
Type	083112	083115	083116	083117	083118
Nominal Current at 100% duty cycle and 35°C [A]	32	60	100	125 ¹⁾	10
Cross Section of Conductor [mm ²]	25	16	25	35	25
Resistance at 35°C [Ω/m]	0.005506	0.001182	0.000745	0.000540	0.029313
Impedance at 18 mm rail spacing [Ω/m]	0.005507	0.001185	0.000750	0.000548	0.029314

1) 140 A at 80% duty cycle

Nominal Voltage [V]	500
Support Spacing max. [mm]	1000
Rail Length [mm]	Standard 4000; intermediate lengths 3000, 2000, 1000
External Dimensions [mm]	3-poles: 26 x 62 4-poles: 26 x 80 5-poles: 26 x 98 (see picture)

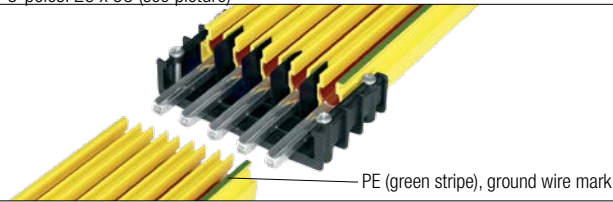

Speed max. [m/min]	600
Ambient Temperature max.	55°C
Ambient Temperature min.	0 to -18°C; depends on the type of standard conductor rail; (special designs for deeper temperatures on request)

Relevante Normen	<p>VDE 0110-1:2008-01 Insulation coordination for electrical equipment in low voltage systems - Part 1: Principles, requirements and tests (IEC 60664-1:2007); German version EN 60664-1:2007</p> <p>DIN EN 60204-1; VDE 0113-1:2007-06 Machine Safety - Electrical Equipment of Machines - Part 1: General requirements (IEC 60204-1:2005, modified); German version EN 60204-1:2006</p> <p>DIN EN 60529; VDE 0470-1:2000-09 Systems of protection through housing (IP-Code) (IEC 60529:1989 + A1:1999); German version EN 60529:1991 A1:2000</p> <p>DIN EN 60243-2; VDE 0303-22:2001-10 Electrical puncture strength of insulating materials - Test procedures- Part 2: Additional requirements for testing with direct current (IEC 60243-2:2001); German version EN 60243-2:2001</p> <p>DIN IEC 60093; VDE 0303-30:1993-12 Testing procedures for electrical insulating materials; specific puncture strength and specific surface strength of fest, electrical insulating materials (IEC 60093:1980); German version HD 429 S1:1983</p> <p>DIN IEC 60167; VDE 0303-31:1993-12 Test procedures for electrical insulating materials, insulation resistance of firm insulating materials (IEC 60167:1964); German version HD 568 S1:1990</p> <p>DIN EN 60112; VDE 0303-11:2003-11 Procedure for the determination of the test number and of the index number of the spark checking of firm insulating materials (IEC 60112:2003); German version EN 60112:2003</p>
------------------	---

Air and Surface Creepage	depending on degree of pollution; surface creepage distance 30 mm to DIN VDE 0110 Part 1 + 2
--------------------------	--

Protection Type	IP 23 with horizontal arrangement IP 21 with vertical arrangement
-----------------	--

Chemical Resistance of the Profile at an Ambient Temperature of +45°C	<table border="0"> <tr> <td>Benzine</td> <td>resistant</td> <td>Sodium hydroxide 25%</td> <td>resistant</td> </tr> <tr> <td>Mineral oil</td> <td>resistant</td> <td>Hydrochlorid acid</td> <td>resistant</td> </tr> <tr> <td>Grease</td> <td>resistant</td> <td>Sulphuric acid up to 50%</td> <td>resistant</td> </tr> </table>	Benzine	resistant	Sodium hydroxide 25%	resistant	Mineral oil	resistant	Hydrochlorid acid	resistant	Grease	resistant	Sulphuric acid up to 50%	resistant
Benzine	resistant	Sodium hydroxide 25%	resistant										
Mineral oil	resistant	Hydrochlorid acid	resistant										
Grease	resistant	Sulphuric acid up to 50%	resistant										

The materials of the conductor rail systems are weather resistant and have got a high resistance against certain chemicals. For special applications please contact us.
Please be careful with solvents and contact sprays.

Note: Additional informations on request.

Conductor Rails

Rails complete with pre-mounted Connector (083112-... / 083115-.... / 083116-..., / 083117-... / 083118- ...)

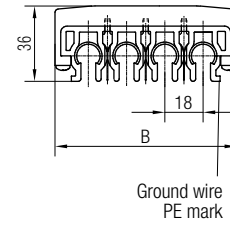
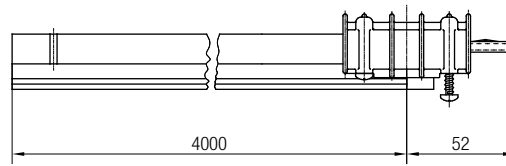
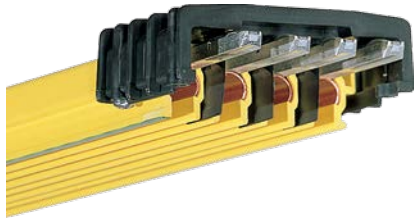

Technical details

- He table shows standard conductor rails.
- Intermediate lengths are available!

Multipole Conductor Rail	Power Supply with PE Order No.	Controls without PE Order No.	Poles	B [mm]	Weight [kg]
Galvanized Steel 32 A	083112-4x3x12	083112-4x3x11	3	72.5	6.280
	083112-4x4x12	083112-4x4x11	4	90.5	8.370
	083112-4x5x12	083112-4x5x11	5	108.5	10.460
Copper 60 A	083115-4x3x12	083115-4x3x11	3	72.5	5.600
	083115-4x4x12	083115-4x4x11	4	90.5	7.474
	083115-4x5x12	083115-4x5x11	5	108.5	9.348
Copper 100 A	083116-4x3x12	083116-4x3x11	3	72.5	6.590
	083116-4x4x12	083116-4x4x11	4	90.5	8.786
	083116-4x5x12	083116-4x5x11	5	108.5	10.982
Copper 125 A	083117-4x3x12	083117-4x3x11	3	72.5	7.520
	083117-4x4x12	083117-4x4x11	4	90.5	10.034
	083117-4x5x12	083117-4x5x11	5	108.5	12.540
Datametal 10 A	083118-4x3x12	083118-4x3x11	3	72.5	6.300
	083118-4x4x12	083118-4x4x11	4	90.5	8.402
	083118-4x5x12	083118-4x5x11	5	108.5	10.504

Order Example: Multipole conductor rail program 0831
steel 32 A
4-poles
for power supply
4 m long

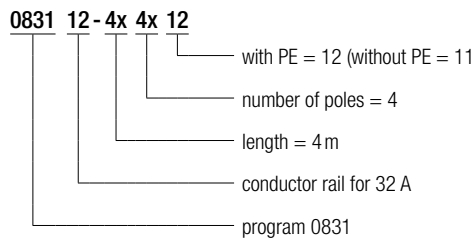

Power Feeds

End Feed complete with pre-mounted Connector and Terminal Box (083153-...)



Technical details

- Connection cable max. 35 mm²
- Suitable for all types of multipole conductor rails
- Use cable lugs for threaded connection M8 (not included)

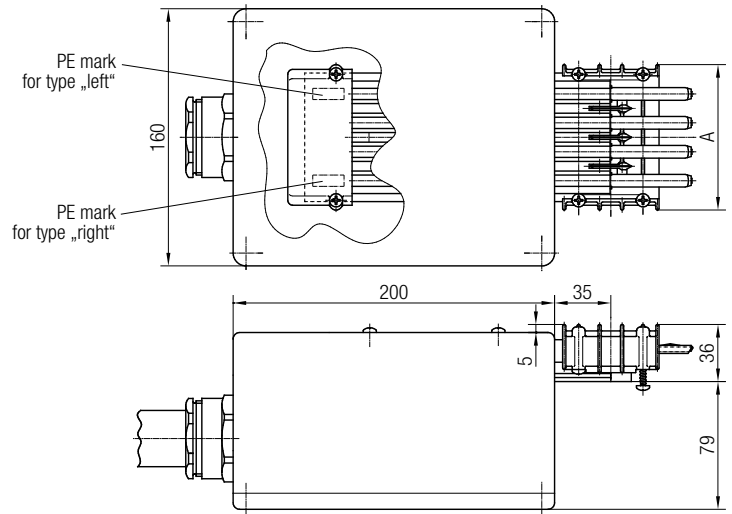

Power Supply with PE type "right" Order No.	Power Supply with PE type "left" Order No.	Controls without PE Order No.	Poles	Gland	A [mm]	Weight [kg]
083153-310x12	083153-310x13	083153-310x11	3	Pg 36	72.5	1.460
083153-311x12	083153-311x13	083153-311x11		Pg 29		1.430
083153-312x12	083153-312x13	083153-312x11		Pg 16		1.410
083153-410x12	083153-410x13	083153-410x11	4	Pg 36	90.5	1.985
083153-411x12	083153-411x13	083153-411x11		Pg 29		1.955
083153-412x12	083153-412x13	083153-412x11		Pg 16		1.935
083153-510x12	083153-510x13	083153-510x11	5	Pg 36	108.5	2.330
083153-511x12	083153-511x13	083153-511x11		Pg 29		2.300
083153-514x12	083153-514x13	083153-514x11		Pg 42		2.365

Line Feed complete with pre-mounted Connector (083151-...)

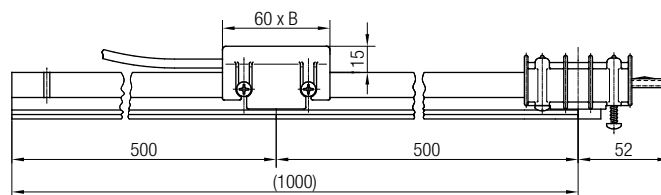

Technical details

- Connection cable max. 10 mm²
- Cable lugs (according to nominal current) are included
- connection screws M5

In-line Feed	Power Supply with PE Order No.	Controls without PE Order No.	Poles	B [mm]	Weight [kg]
for Steel Rail 32 A	083151-32x12	083151-32x11	3	72.5	1.800
	083151-42x12	083151-42x11	4	90.5	2.400
	083151-52x12	083151-52x11	5	108.5	3.000
for Copper Rail 60 A	083151-35x12	083151-35x11	3	72.5	1.630
	083151-45x12	083151-45x11	4	90.5	2.175
	083151-55x12	083151-55x11	5	108.5	2.720
for Datametal Rail 10 A	083151-38x12	083151-38x11	3	72.5	1.800
	083151-48x12	083151-48x11	4	90.5	2.400
	083151-58x12	083151-58x11	5	108.5	3.000

Power Feeds

Line Feed complete with pre-mounted Connector (083154-...)

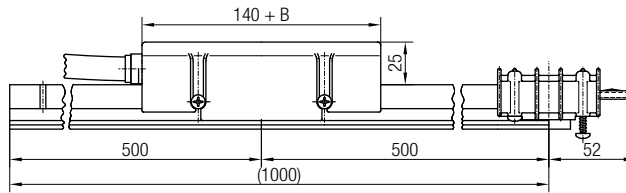

Technical details

- Connection cable max. 35 mm²
- Cable lugs (according to nominal current) are included
- connection screws M6

In-line feed	Power Supply with PE Order No.	Controls without PE Order No.	Poles	B [mm]	Weight [kg]
Steel Rail 32 A	083154-32x12	083154-32x11	3	72.5	1.925
	083154-42x12	083154-42x11	4	90.5	2.525
	083154-52x12	083154-52x11	5	108.5	3.120
Copper Rail 60 A	083154-35x12	083154-35x11	3	72.5	1.750
	083154-45x12	083154-45x11	4	90.5	2.300
	083154-55x12	083154-55x11	5	108.5	2.850
Copper Rail 100 A	083154-36x12	083154-36x11	3	72.5	2.010
	083154-46x12	083154-46x11	4	90.5	2.630
	083154-56x12	083154-56x11	5	108.5	3.250
Copper Rail 125 A	083154-37x12	083154-37x11	3	72.5	2.240
	083154-47x12	083154-47x11	4	90.5	2.940
	083154-57x12	083154-57x11	5	108.5	3.650

Line Feed complete with pre-mounted Connector and Terminal Box (083152-...)

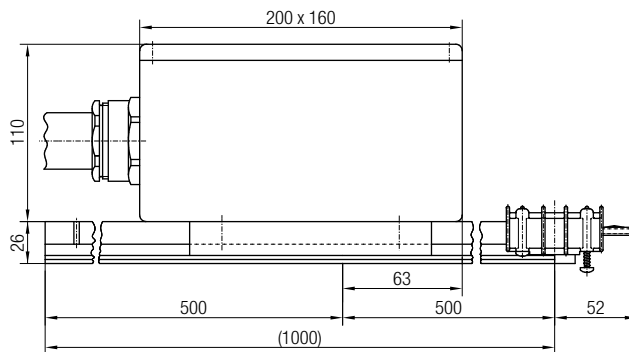

Technical details

- Connection cable max. 35 mm²
- Use cable lugs for threaded connection M8 (not included)

In-line feed	Power Supply with PE Order No.	Controls without PE Order No.	Poles	Gland	Weight [kg]
Steel Rail 32 A	083152-323x12	083152-323x11	3	Pg 21	3.000
	083152-421x12	083152-421x11	4	Pg 29	3.720
	083152-521x12	083152-521x11	5	Pg 29	4.600
Copper Rail 60 A	083152-353x12	083152-353x11	3	Pg 21	2.430
	083152-451x12	083152-451x11	4	Pg 29	3.190
	083152-551x12	083152-551x11	5	Pg 29	3.950
Copper Rail 100 A	083152-360x12	083152-360x11	3	Pg 36	2.680
	083152-460x12	083152-460x11	4	Pg 36	3.520
	083152-564x12	083152-564x11	5	Pg 42	4.350
Copper Rail 125 A	083152-370x12	083152-370x11	3	Pg 36	2.920
	083152-470x12	083152-470x11	4	Pg 36	3.830
	083152-574x12	083152-574x11	5	Pg 42	4.730

Hanger Clamps

For Conductor Rail Snap-in with Steel Nut (083143-...)

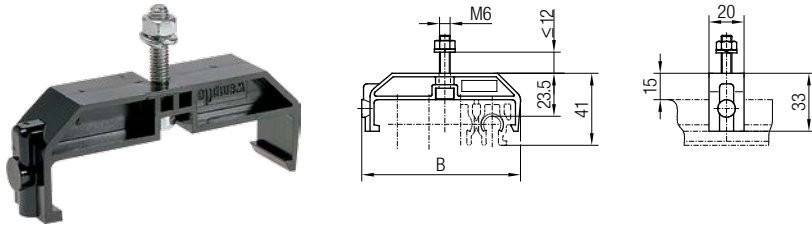

Order No.	Poles	max. Support Spacing [mm]	B [mm]	Weight [kg]
083143-3	3	1000	72.5	0.023
083143-4	4		90.5	0.025
083143-5	5		108.5	0.028

For Conductor Rail Snap-in for Support Arm Installation (083145-...)

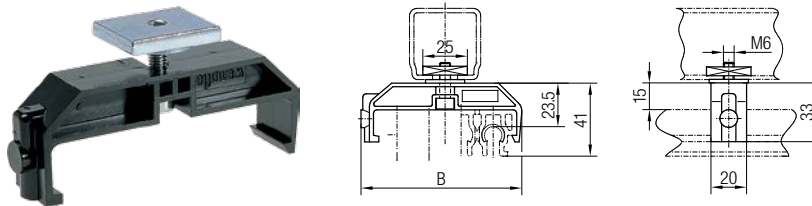

Order No.	Poles	max. Support Spacing [mm]	B [mm]	Weight [kg]
083145-3	3	1000	72.5	0.053
083145-4	4		90.5	0.055
083145-5	5		108.5	0.058

With Universal Steel Clamp Fastener for Vertical Installation (083146-...)

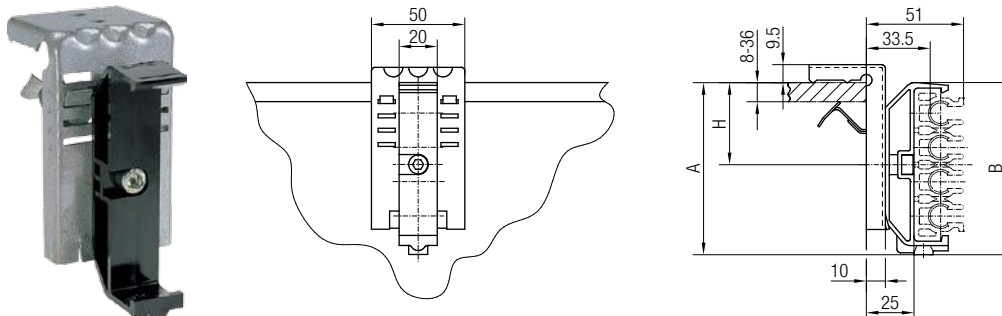

Technical details

- For system lengths of more than 10 m it is recommended to secure at least, every tenth hanger clamp with an additional screw (see installation instruction MV0831-0003).
- Universal steel clamp fastener, galvanized
- clamping range 8 to 36 mm

Order No.	Poles	max. Support Spacing [mm]	A [mm]	B [mm]	H [mm]	Weight [kg]
083146-3	3	1000	81.5	72.5	43	0.113
083146-4	4		90.5	90.5	43	0.115
083146-5	5		111.5	108.5	55	0.118

Anchor Clamps

For Conductor Rail Snap-in and Fixation with Steel Nut (083133-...)

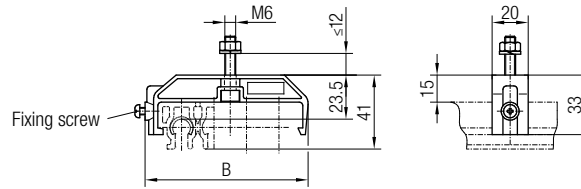
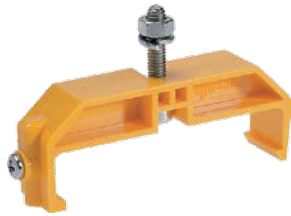

Order No.	Poles	B [mm]	Weight [kg]
083133-3	3	72.5	0.027
083133-4	4	90.5	0.030
083133-5	5	108.5	0.033

For Conductor Rail Snap-in and Fixation for Support Arm Installation (083135-...)

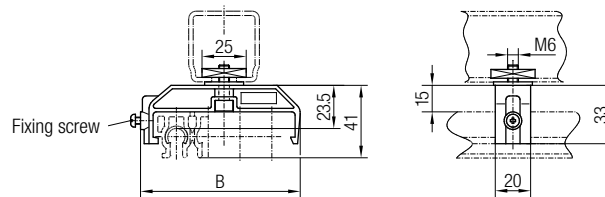

Order No.	Poles	B [mm]	Weight [kg]
083135-3	3	72.5	0.057
083135-4	4	90.5	0.060
083135-5	5	108.5	0.063

For Conductor Rail Snap-in and Fixation (083136-... / 083137-...)

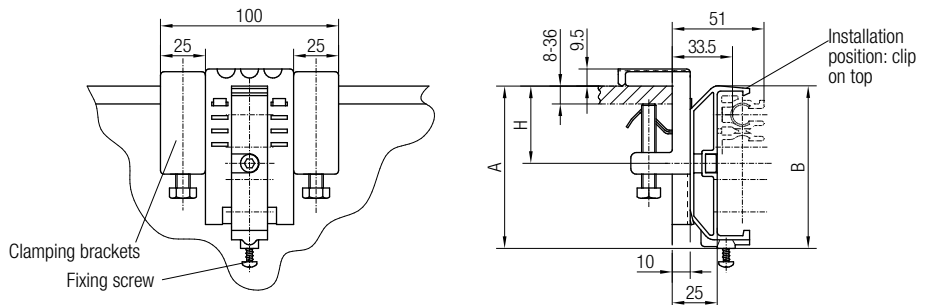

Technical details

- The anchor clamp 083137-... is identical with 083136-..., but without clamping brackets
- The plastic parts are coloured in orange!

Anchor Clamp	Order No.	Poles	A [mm]	B [mm]	H [mm]	Weight [kg]
for support arm installation	083136-3	3	81.5	72.5	72.5	0.337
	083136-4	4	90.5	90.5	90.5	0.340
	083136-5	5	111.5	108.5	108.5	0.343
with universal clamp fastener ¹⁾ for systems up to 60 m length	083137-3	3	81.5	72.5	72.5	0.117
	083137-4	4	90.5	90.5	90.5	0.120
	083137-5	5	111.5	108.5	108.5	0.123

1) Universal steel clamp fastener; galvanized; clamping range 8 to 36 mm

End Caps

For System Ends (083171-...)

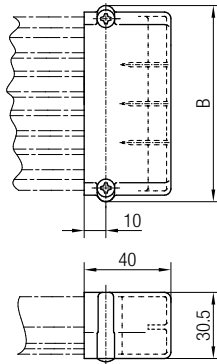

Order No.	Poles	B [mm]	Weight [kg]
083171-3	3	72.5	0.040
083171-4	4	90.5	0.045
083171-5	5	108.5	0.050

For Transfer Points (083172-...)

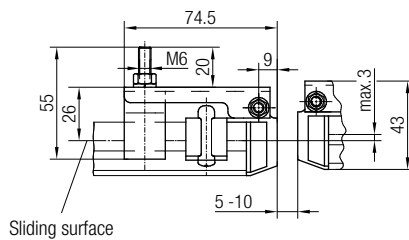
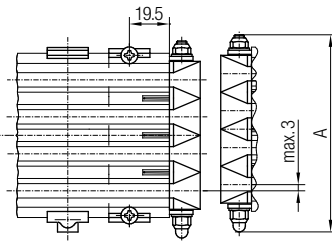
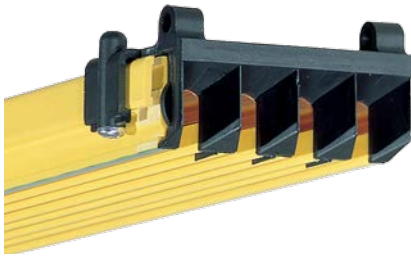

Technical details

- The end cap for transfer points centres the current collector and compensates horizontal and vertical deflections of max. ± 3 mm.

Order No.	Poles	B [mm]	Weight [kg]
083172-3	3	77	0.160
083172-4	4	95	0.200
083172-5	5	113	0.240

Air Gap Insulating Sections Pick-up Guides

Air Gap Insulating Sections (083195-...)

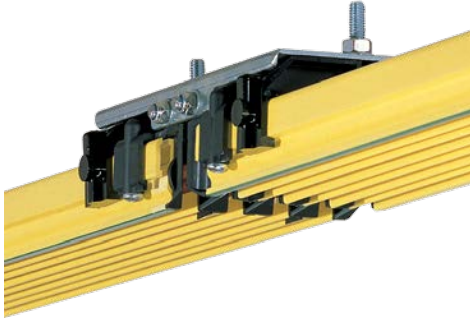

Technical details

- Not usable in combination with current collector 083102

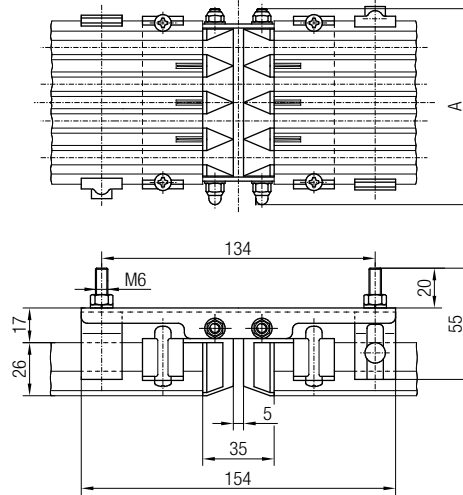

Order No.	Poles	A [mm]	Weight [kg]
083195-3	3	77	0.342
083195-4	4	95	0.418
083195-5	5	113	0.494

Pick-up Guides for Transfer Points (083181-....)

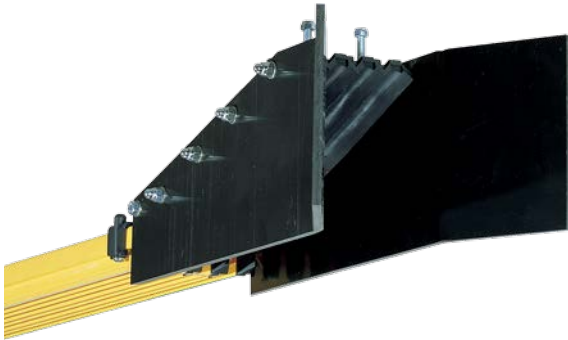

Technical details

- Use pick-up guides only with "pick-up guide current collector".
- The pick-up guide compensates vertical or horizontal misalignments up to ± 15 mm. Assembly tolerances below ± 3 mm are recommended.

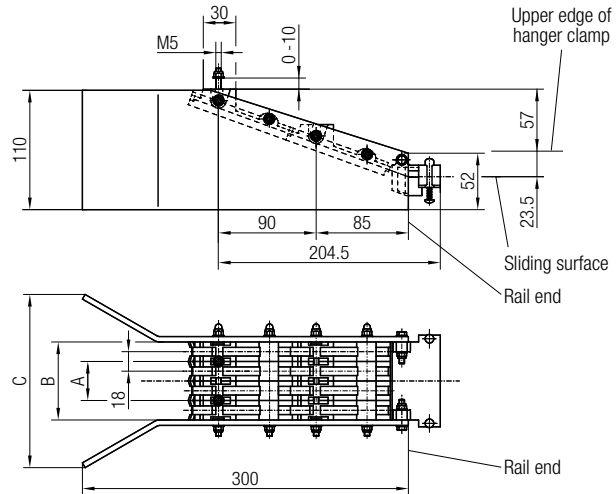

Order No.	Poles	A [mm]	B [mm]	C [mm]	Weight [kg]
083181-3x25	3	18	54	142	0.160
083181-4x25	4	36	72	160	0.200
083181-5x25	5	54	90	178	0.240

Expansion Element

Complete with pre-mounted Connector (083161-...)



Note
Copper-Expansion Element can be used for all copper and steel conductor rails up to 125 A

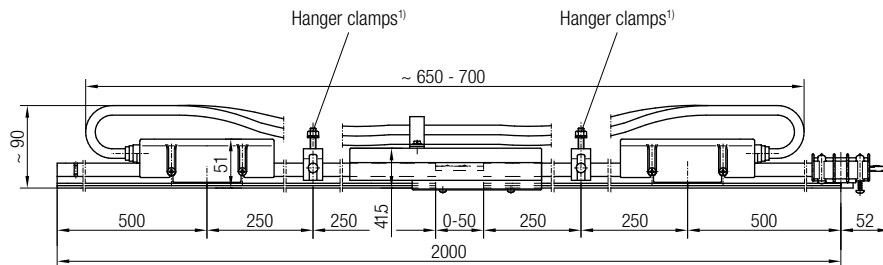

1) Hanger clamps to be ordered separately! Connecting cables have to be installed flexible.

Expansion Elements with PE Order No.	without PE Order No.	Poles	Material	Weight
				[kg]
083161-2x6372	083161-2x6371	3	Copper	5.610
083161-2x6472	083161-2x6471	4		7.480
083161-2x6572	083161-2x6571	5		9.350
083161-2x2382	083161-2x2381	3	Datametal	2.810
083161-2x2482	083161-2x2481	4		3.720
083161-2x2582	083161-2x2581	5		4.680

See hints page 12 (dimensioning / quantity).

How to select Expansion Elements

Expansion elements are installed in systems exceeding a total system length of 200 m as shown below, if the ambient temperature variation (ΔT) is more than 20°C during operation. Expansion joints are not required if the total system length is shorter than 200 m or if the ambient temperature variation (ΔT) is below 20°C during operation. An anchor clamp in the middle of the system halves the expansion travel and eases positioning of the hanger clamps.

Pay attention to the distance between the hanger clamps and the rail connectors (System sketch, page 23).

Determination of System Length L:

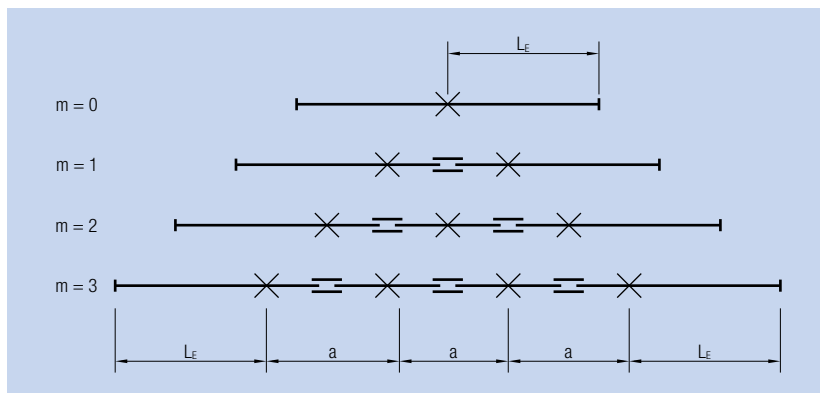

System length L:
 $L = 2 \cdot L_E + m \cdot a$

Number of expansion elements:

$$m = \frac{L - 200}{a} \text{ (rounded)}$$

m = number of system part lengths with one expansion element

Expansion Element

Determination Quantity of Expansion Elements

ΔT [°C]	a [m] ¹⁾	System length [m]							
		220	240	260	280	300	320	340	360
65	11	2	4	6	8	10	11	13	15
60	12	2	4	5	7	9	10	12	14
55	14	2	3	5	6	8	9	10	12
50	15	2	3	4	6	7	8	10	11
45	17	2	3	4	5	6	8	9	10
40	20	1	2	3	4	5	6	7	8
35	24	1	2	3	4	5	5	6	7
30	31	1	2	2	3	4	4	5	6
25	40	1	1	2	2	3	3	4	4
20	60	1	1	1	2	2	2	3	3

1) number of needed expansion elements

Diagram to set the Air Gap of Expansion Elements

Air gap to be set 0 - 50 mm during system installation.

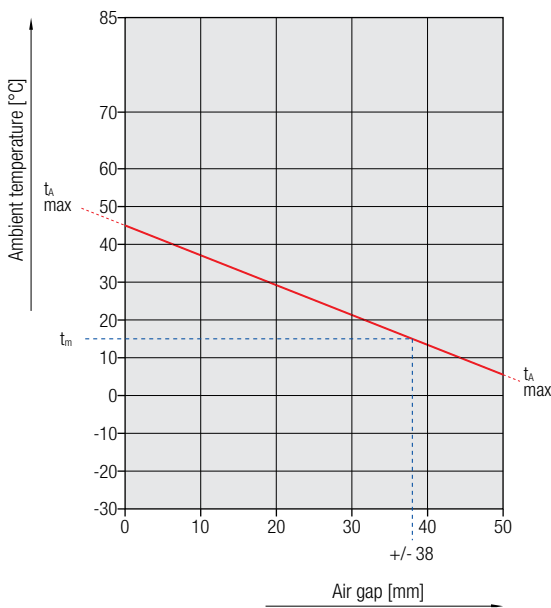

How to use the diagram (Example below):

1. Draw a connection line from min. to max. ambient temperature t_a (e.g. 5°C to 45°C).
2. Mark the ambient temperature during installation t_m (horizontal dotted line).
3. Draw a line from the intersection vertically down and read the air gap to adjust.

Technical details

- Highest ambient temp.: 55°C
- Lowest ambient temp.: 0 to -18°C; depends on the type of conductor rail. Special designs for deeper temperatures on request.

Example

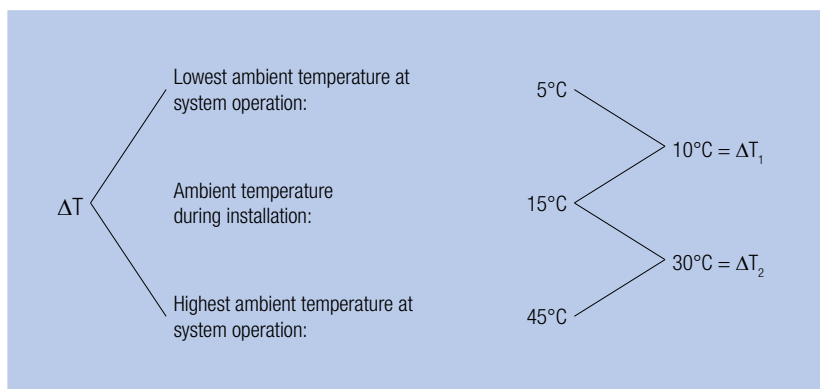

Air gap read from diagram: ~ 38 mm

Air gap calculated:

$$s = 50 \frac{\Delta T_2}{\Delta T_1 + \Delta T_2} = 38 \text{ mm}$$

Current Collectors with Accessories

Current Collectors (083102-...)

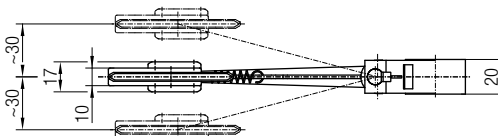
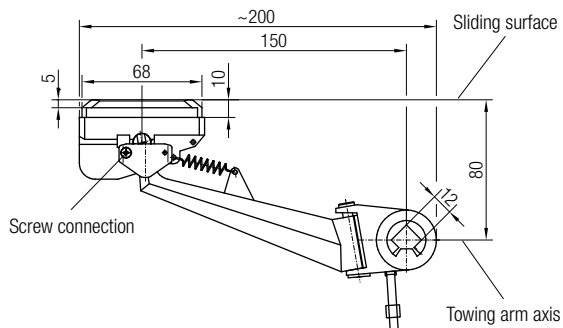

Technical details

- Collector shoe material: copper graphite
- Max. wearing height: 5 mm
- Contact pressure: 5 N
- Deflection (horizontal/vertical): ± 30 mm
- Assembly tolerances below ± 10 mm recommended
- **Connection cables (highly flexible) to be ordered separately (see page 15)**
- **The current collectors are not for use with program 0811!**
- **Do not use in combination with air gap insulation 083195 and transfer points 083172**

Type	with Phase (PH) Order No.	with Earth (PE) Order No.	I max. ¹⁾ [A]	Weight [kg]
Current Collector	083102-0021	083102-0022	55	0.120
Current Collector for Transfer Points	083102-3021	083102-3022	55	0.125

1) Depending on cross section of connection cable; limit 55A

Collector Support Brackets 081050-.... (for current collector 083102-...)

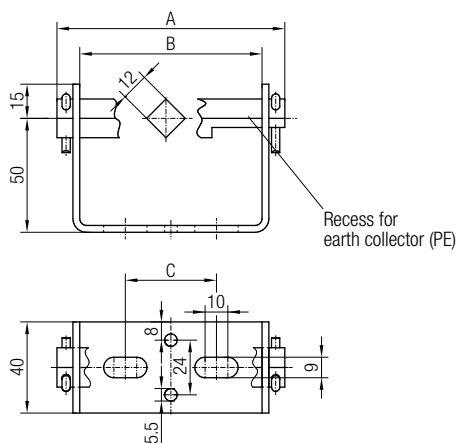
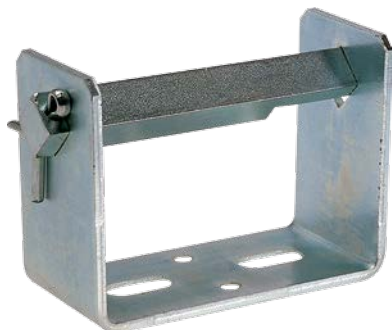

Order No.	Poles	A [mm]	B [mm]	C [mm]	Weight [kg]
081050-20x3	3	80	60	30	0.300
081050-20x4	4	100	80	40	0.370
081050-20x5	5	120	100	50	0.440

Current Collectors and Accessories

Current Collectors 083106-...

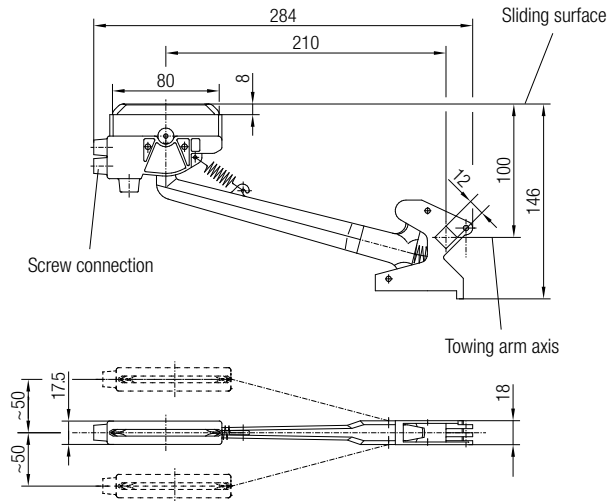
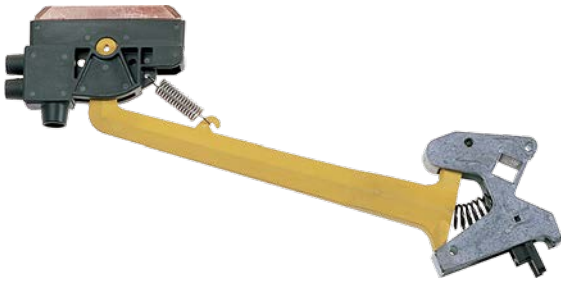

Technical details

- Collector shoe material: copper graphite
- Max. wearing height: 8 mm
- Contact pressure: 10 N
- Deflection (horizontal/vertical): ± 50 mm
- Assembly tolerances below ± 10 mm recommended
- Connection cables (highly flexible) to be ordered separately (see page 15)
- The current collectors can also be used for transfer points

Expansion Joints with Phase (PH)		I max. ¹⁾ [A]	Weight [kg]
Order No.	Earth (PE) Order No.		
083106-0021	083106-0022	80	0.270

1) Depending on cross section of connection cable; limit 80 A.

Collector Support Brackets 083050-... (for current collector 083106-...)

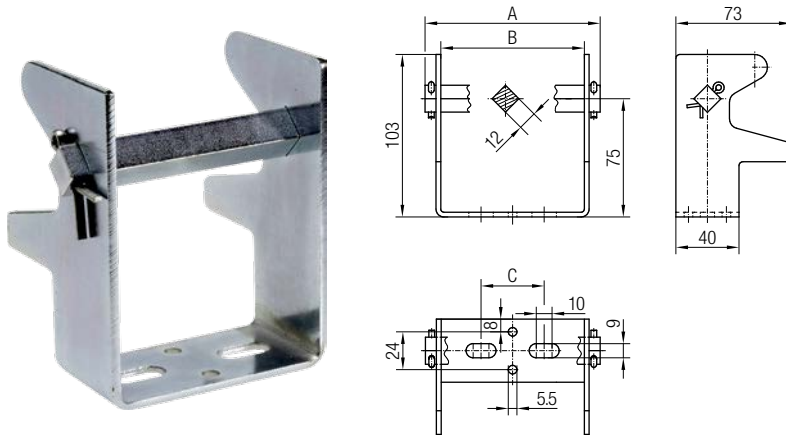

Order No.	Poles	A [mm]	B [mm]	C [mm]	Weight [kg]
083050-18x3	3	74	55.0	30	0.300
083050-18x4	4	92	73.0	40	0.370
083050-18x5	5	110	91.5	50	0.440

Current Collectors and Accessories

Support Spring Plates 08-F030-...

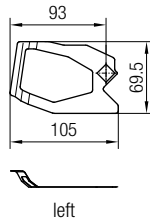

left

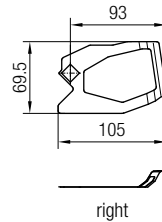

right

Technical details

- Position and type see current collector unit 083107-...
- For horizontal operation of the current collector unit
- Use only with collector support bracket 083050-...

Order No.	Support Spring Plate	Weight [kg]
08-F030-0082	left	0.013
08-F030-0079	right	

Connection Cable with Multicore Cable End Jacket 081109-...

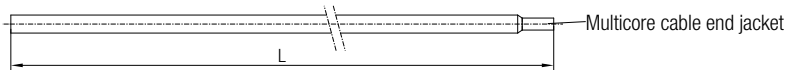

Cross Section [mm ²]	Connection Cable with Phase (PH) Order No.	Earth (PE) Order No.	Length ¹⁾ [m]	Weight [kg/m]	Cable Diameter [mm]	I at 100% Duty Cycle [A]	Use for
1.5	081109-1x1.5x11	081109-1x1.5x32	1	0.014	4	24	083102-... 083103-... 083104-... 083106-... 083107-...
2.5	081109-1x2.5x11	081109-1x2.5x32	1	0.023	4	34	
4	081109-1x4 x11	081109-1x4 x32	1	0.037	5	42	
6	081109-1x6 x11	081109-1x6 x32	1	0.056	8	54	
1.5	081109-2x1.5x11	081109-2x1.5x32	2	0.014	4	24	
2.5	081109-2x2.5x11	081109-2x2.5x32	2	0.023	4	34	
4	081109-2x4 x11	081109-2x4 x32	2	0.037	5	42	
6	081109-2x6 x11	081109-2x6 x32	2	0.056	6	54	

1) Intermediate lengths are available

Please note:

The connection cable is highly flexible and double insulated and must be ordered in the required length and size. Amperage for single-core cables installed free in air according to DIN VDE 57 100 part 523.

Connection Cable 081109-..., 081209-...

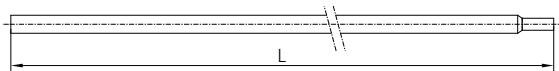

Cross Section [mm ²]	Connection Cable with Phase (PH) Order No.	Earth (PE) Order No.	Length ¹⁾ [m]	Weight [kg/m]	Cable Diameter [mm]	I at 100% Duty Cycle [A]	Use for
10	081109-1x10 x91	081109-1x10 x92	1	0.098	7	73	083106-... 083107-...
16	081209-1x16 x81	081209-1x16 x82	1	0.156	10	98	
10	081109-1x10 x91	081109-1x10 x92	2	0.098	7	73	
16	081209-2x16 x81	081209-2x16 x82	2	0.156	10	98	

1) Intermediate lengths are available

Please note:

The connection cable is highly flexible and double insulated and must be ordered in the required length and size. Amperage for single-core cables installed free in air according to DIN VDE 57 100 part 523.

Current Collector Units

Current Collector Units without Terminal Boxes 083103-...

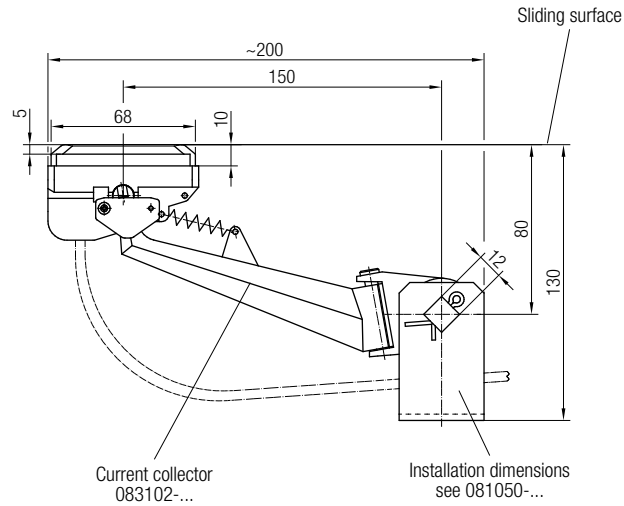
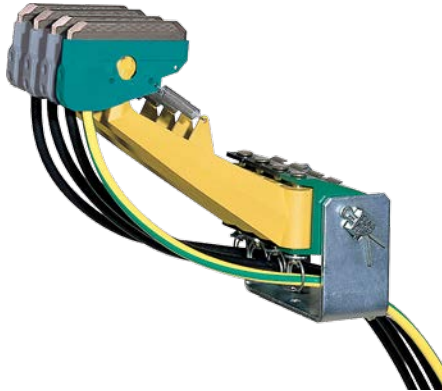

Technical details

- Shown is the version for „pick-up guides for transfer points“
- Collector shoe material: copper graphite
- Contact pressure per collector arm: 5 N
- Max. current load:
55 A with 6 mm² connection cable at 100% duty cycle
34 A with 2.5 mm² connection cable at 100% duty cycle
- Deflection (horizontal/vertical): ±30 mm
- Assembly tolerances below ±10 mm recommended
- **Connection cables (highly fl exible) to be ordered separately (see page 15)**
- **The current collector units are not for use with program 0811!**
- **Other connection cable cross sections on request**
- To arrange above as double-current-collectors separate order no. for the complementary units are required due to PE-orientation. Please contact sales dpt.

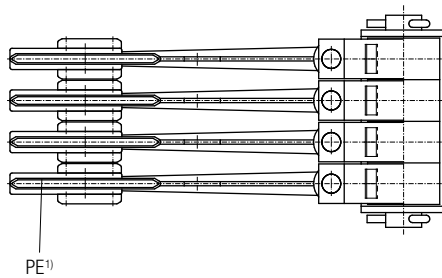

1) Position of earth collectors for version „with PE“

Current Collector Unit	Standard Order No.	for Transfer Points Order No.	Poles	Weight [kg]
for power supply; with PE; connection cable 6 mm ² , 1 m long	083103-030023	083103-033023	3	0.690
	083103-040023	083103-043023	4	0.890
	083103-050023	083103-053023	5	1.090
for controls; without PE; connection cable 2.5 mm ² , 1 m long	083103-030021	083103-033021	3	0.690
	083103-040021	083103-043021	4	0.890
	083103-050021	083103-053021	5	1.090

Current collector Units

Current Collector Units without Terminal Boxes 083107-...

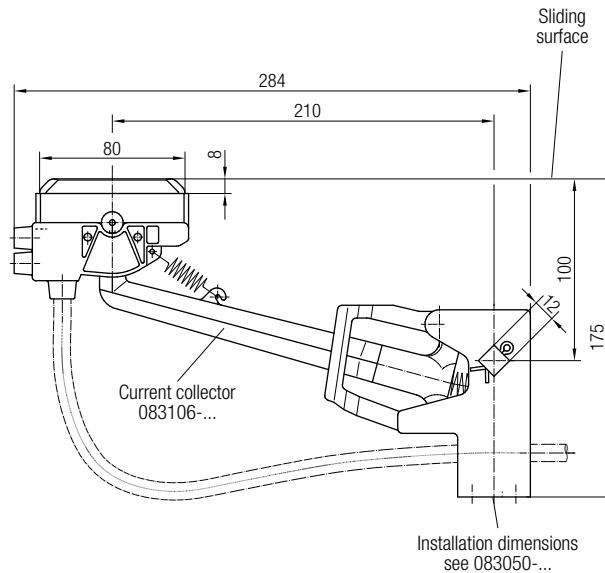
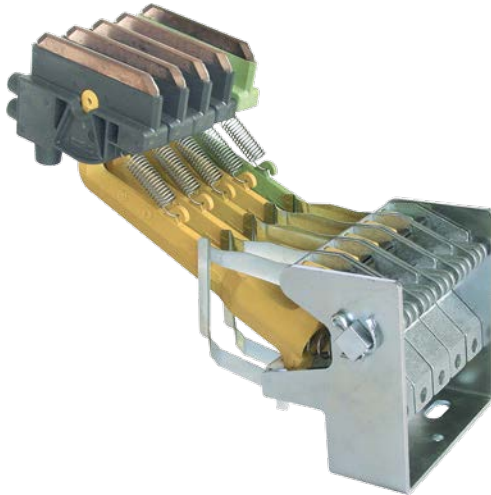

Technical details

- Shown is the version for horizontal operation
- Collector shoe material: copper graphit
- Contact pressure per collector arm: 10 N
- Max. current load: 80 A with 16 mm² connection cable at 100% duty cycle
- Deflection (horizontal/vertical): ± 50 mm
- Assembly tolerances below ± 10 mm recommended
- **Connection cables (highly flexible) to be ordered separately (see page 15)**
- **The current collector units can also be used for „pick-up guides for transfer points“**
- **Other connection cable cross sections on request**
- To arrange above as double-current-collectors separate order no. for the complementary units are required due to PE-orientation. Please contact sales dpt.

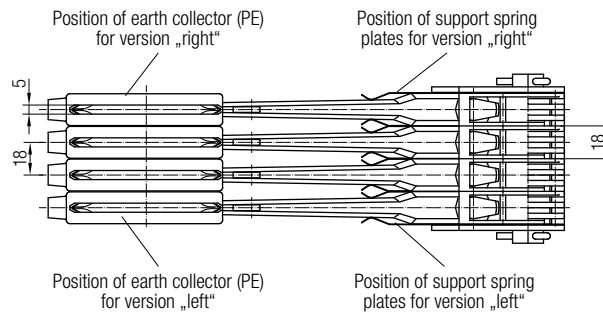

Current Collector Unit	without PE Order No.	with PE Order No.	Poles	Weight [kg]
for vertical operation	083107-030023	083107-030021	3	0.860
	083107-040023	083107-040021	4	1.410
	083107-050023	083107-050021	5	1.960
for horizontal operation with support spring plates "right"	083107-036023	083107-036021	3	0.890
	083107-046023	083107-046021	4	1.440
	083107-056023	083107-056021	5	1.990
for horizontal operation with support spring plates "left"	083107-037023	083107-037021	3	0.890
	083107-047023	083107-047021	4	1.440
	083107-057023	083107-057021	5	1.990

Current Collector Units

Current Collector Units with Terminal Boxes 083103-...

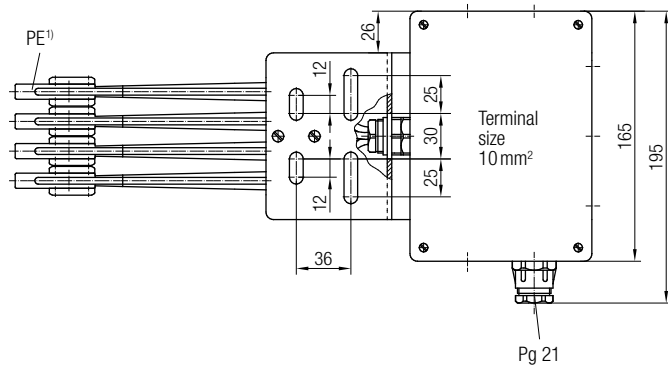
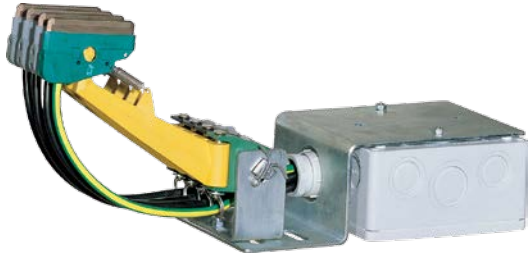

Technical details

- Collector shoe material: copper graphit
- Contact pressure per collector arm: 5 N
- Max. current load:
55 A with 6 mm² connection cable at 100% duty cycle
34 A with 2.5 mm² connection cable at 100% duty cycle
- Deflection (horizontal/vertical): ± 30 mm
- Assembly tolerances below ± 10 mm recommended

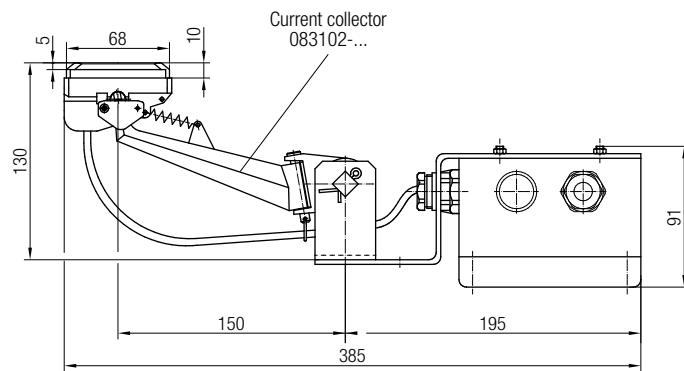

1) Position of earth collector for version „with PE“.

Current Collector Unit	without PE Order No.	with PE Order No.	Poles	Weight [kg]
for power supply; connection cable 6 mm ²	083103-130023	083103-130024	3	2.010
	083103-140023	083103-140024	4	2.130
	083103-150023	083103-150024	5	2.250
for controls; connection cable 2.5 mm ²	-	083103-130021	3	2.010
	-	083103-140021	4	2.130
	-	083103-150021	5	2.250

Current Collector Units

Double Current Collector Units for Power Supply; with Terminal Boxes 083104-...

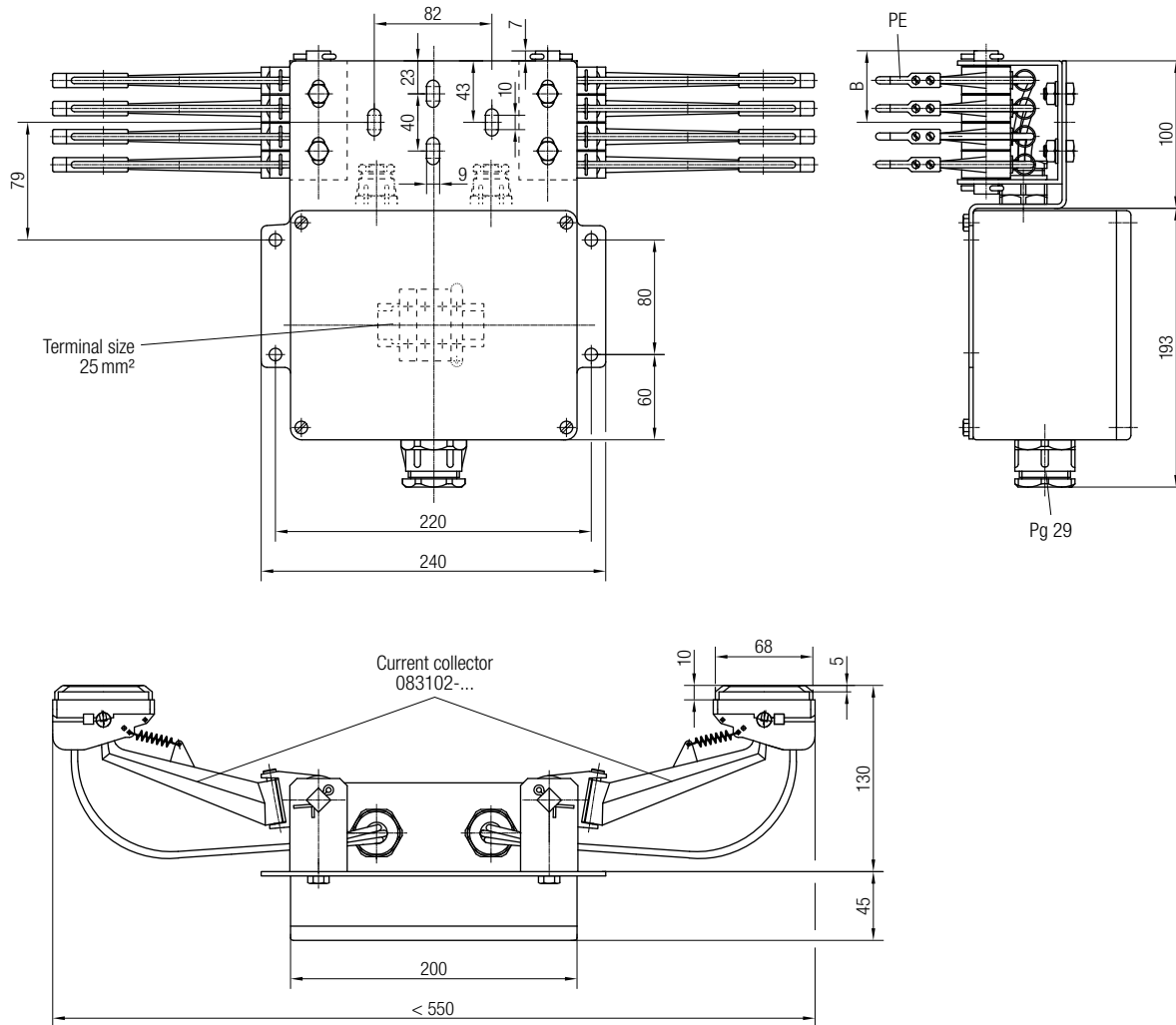

Technical details

- Collector shoe material: copper graphit
- Contact pressure per collector arm: 5 N
- Deflection (horizontal/vertical): ± 30 mm
- Assembly tolerances below ± 10 mm recommended
- Max. current load:
110 A (2 x 55 A) with 6 mm² connection cable at 100% duty cycle
34 A with 2.5 mm² connection cable at 100% duty cycle

Double Current Collector Unit	Order No.	Poles	B [mm]	Weight [kg]
for power supply with PE; connection cable 6 mm ²	083104-130023	3	40	4.130
	083104-140023	4	50	4.245
	083104-150023	5	60	4.370

Current Collector Units

Double Current Collector Units for Control; with Terminal Boxes (083104-...)

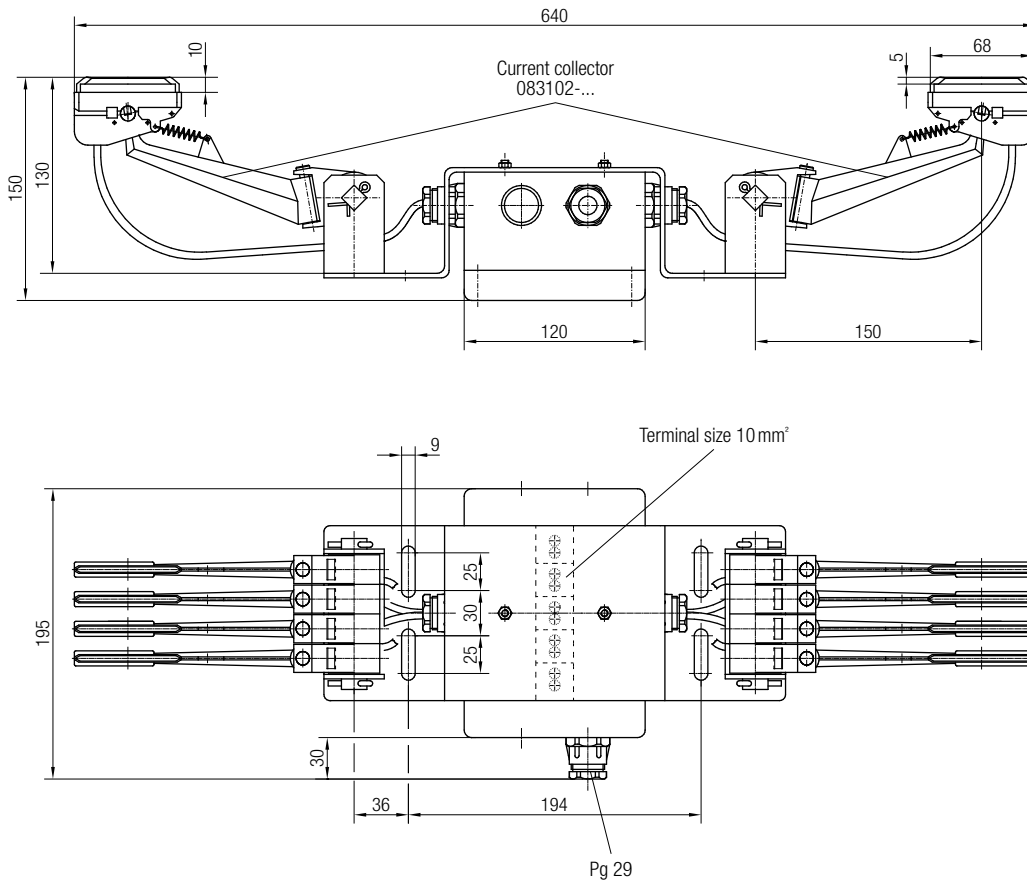

Technical details

- Collector shoe material: copper graphit
- Contact pressure per collector arm: 5 N
- Deflection (horizontal/vertical): ± 30 mm
- Assembly tolerances below ± 10 mm recommended

- Max. current load: 68 A (2 x 34 A) with 2.5 mm² connection cable at 100% duty cycle

- The current collector units are not for use with program 0811!
- Do not use in combination with air gap insulation 083195 and transfer points 083172

Double Current Collector Unit	Order No.	Poles	Weight [kg]
for control without PE; connection cable 2.5 mm ²	083104-130021	3	4.040
	083104-140021	4	4.155
	083104-150021	5	4.270

Wearing and Spare Parts

Rail Connectors (083121-...)

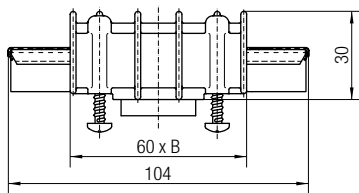

Technical details

- The rail connector is enclosed in the delivery of the rail segments but can be ordered separately.

Steel and Datametal Rail Order No.	Copper Rail Order No.	Poles	B [mm]	Weight [kg]
083121-32	083121-36	3	72.5	0.120
083121-42	083121-46	4	90.5	0.150
083121-52	083121-56	5	108.5	0.180

Collector Shoes 55 A (083002-...)

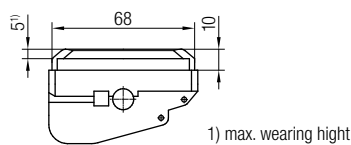

Technical details

- Not interchangeable with collector shoes program 0811

Note:

In plants with transfer points 1 set of spacer pieces with screws Art. No. 08-D002-0592 is to be planned per collector shoe.

Collector Shoes with Phase (PH) Order No.	with Earth (PE) Order No.	Material	Colours	I [A]	for Current Collectors and Current Collector Untis	Weight [kg]
083002-1x4	083002-2x4	Copper-Graphite	PH: grey PE: turquoise-green	55	083102-... / 083103-... 083104-...	0.045
083002-1x5	083002-2x5	Silver-Graphite		10		0.050

Collector Shoes 80 A (081001-...)

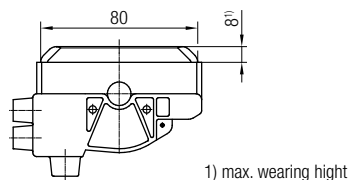

Collector Shoes with Phase (PH) Order No.	with Earth (PE) Order No.	Colours	I [A]	for Current Collectors and Current Collector Untis	Weight [kg]
081001-12	081001-22	PH: black; PE: green	80	083106-... / 083107-...	0.090

Stabilizing Springs for Current Collector Head (RZ-...)

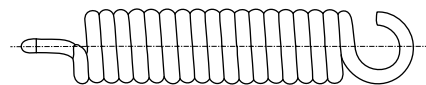

Order No.	for Current Collector	Carbon Length [mm]
08-RZ-056I	083102-... / 083103-... / 083104-...	68
08-RZ-081GI	083106-... / 083107-...	80

Mounting Accessories

Support Arm (020185-....)

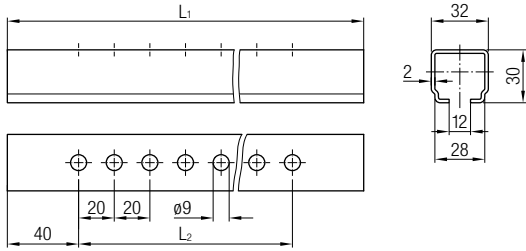

Technical details

- Material: galvanized steel
- Static values: $I_x = 2.11 \text{ cm}^4$
 $W_x = 1.36 \text{ cm}^3$

Order No.	L ₁ [mm]	L ₂ [mm]	Weight [kg]
020185-0250	250	200	0.390
020185-0315	315	260	0.500
020185-0400	400	340	0.625
020185-0500	500	340	0.780
020185-0630	630	340	0.980
020185-0800	800	340	1.245
020185-1000	1000	340	1.550
020185-1250	1250	340	1.945

Permissible Loading for Support Arm

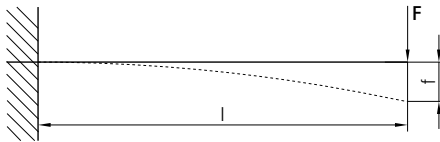

F [daN] 1)	l [m]							
	0.25	0.32	0.40	0.50	0.63	0.80	1.00	1.25
f [cm]	0.08	0.13	0.20	0.32	0.50	0.80	1.25	2.23

1) Calculated with $\sigma = 140 \text{ N/mm}^2$; f = corresponding max. deflection

Girder Clip (020180-...)

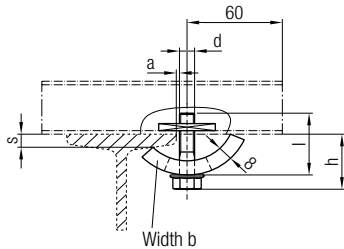

020180-08

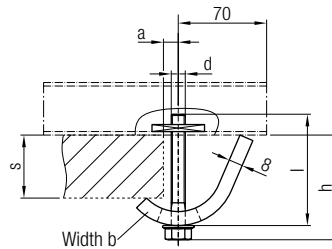

020180-08x36

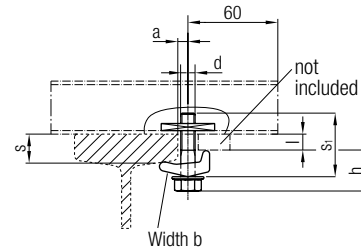

020180-10 / 020180-12

Order No.	Clamping Range s [mm]	d	l [mm]	Installation High h [mm]	b [mm]	a [mm]	s1 [mm]	Material	Weight [kg]
020180-08	04 - 20	M80	50	31 - 40	30	06	-	Galvanized Steel	0.150
020180-08x36	18 - 36	M80	65	42 - 60	30	06	-		0.220
020180-10	06 - 11	M10	50	35 - 41	32	08	-		0.170
	11 - 16			41 - 46			05		
020180-12	16 - 21	M12	60	46 - 51	38	10	10		0.240
	06 - 14			39 - 47			-		
	14 - 22			47 - 55			08		
	22 - 30			55 - 63			16		

Weld-on Bracket (020285) for Support Arm 020185

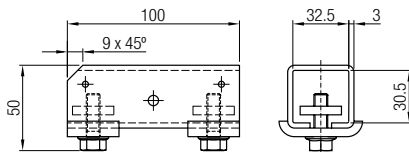

Order No.	Bracket	Material Counter Plate	Hardware	Weight [kg]
020285	Steel, Plain	Galvanized Steel	Galvanized Steel	0.420

Arrangement Examples

System Sketch

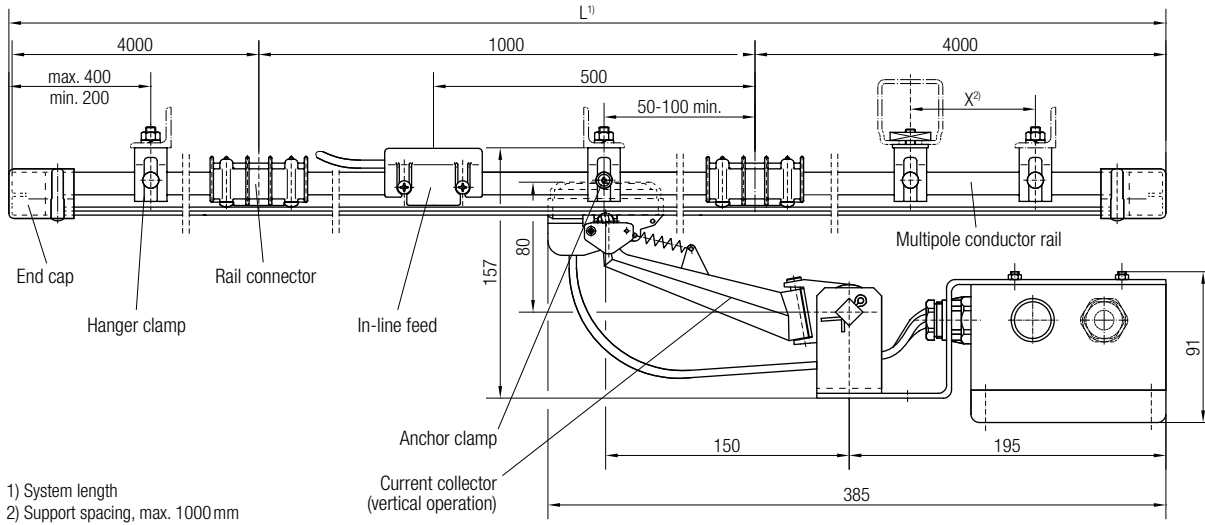

Multipole Conductor Rail Vertical Arrangements

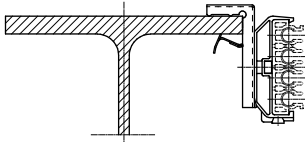

Installation with universal steel clamp fastener (clamping range 8 to 36 mm).

Multipole Conductor Rail Horizontal Arrangements

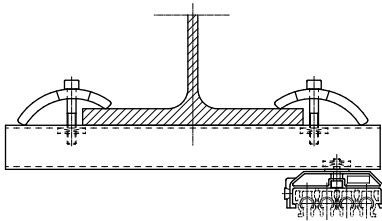

Mounting on support arms with hanger clamps for support arm installation.

Multipole Conductor Rail Horizontal Arrangements

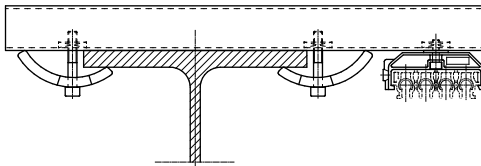

Mounting on support arms with hanger clamps for support arm installation.



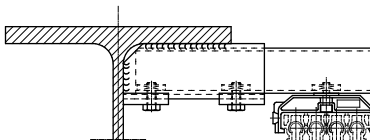

Multipole Conductor Rail Horizontal Arrangements

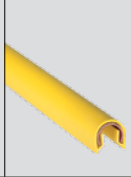

Mounting on support arms with weld-on brackets with hanger clamps for support arm installation

Program Overview

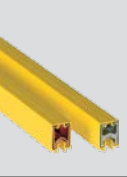
Conductor Rails

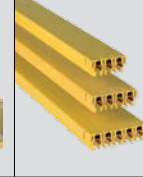
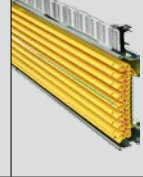
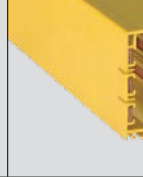
System Designs		Single Pole Insulated Conductor Rail				Multipole Conductor Rail		Enclosed Conductor Rail
Conductor Rail System		Progr. 0811	Progr. 0815	Progr. 0812	Progr. 0813	Progr. 0831	Progr. 0832	Progr. 0842
								
Nominal Current ¹⁾	[A]	10-100	100	25-400	200-1250	10-125 ³⁾	25-200 ⁴⁾	35-140 ⁵⁾
Voltage Grade	[V]	500	500	690	690	500	690	600
Support Spacing	[m]	0.4-1.0	0.5	1.5	2.5	1	3,2	2
Rail Length ²⁾	[mm]	4000	4000	4000	5000	4000	4000	4000
Outside-Dimensions	[mm]	14.7 x 15.5	9.6 x 15.2	18 x 26	32 x 42	3-pol.: 26 x 62 4-pol.: 26 x 80 5-pol.: 26 x 98	4-pol.: 200 x 50	5-pol.: 7-pol.: 56 x 90

1) At 100% duty cycle and 35°C; 2) Standard; 3) 140 A at 80% duty cycle; 4) 200 A at 80% duty cycle; 5) 160 A at 80% duty cycle

General Hints

We reserve the right to carry out any modification of the product at any time in the course of technical progress without prior notice.

All our equipment is in accordance with CE.

Our general terms of business are effective. We shall send them to you on request.

Reprint, even of extracts, is only permitted with our approval.

Your Applications - our Solutions!

Conductor rails by Conductix-Wampfler represent only one of the many solutions made possible by the broad spectrum of Conductix-Wampfler components for the transport of energy, data and fluid media. The solutions we deliver for your applications are based on your specific requirements. In many cases, a combination of several different Conductix-Wampfler systems can prove advantageous. You can count on all of Conductix-Wampfler's Business Units for hands-on engineering support - coupled with the perfect solution to meet your energy management and control needs.



Cable reels

Motorized reels and spring reels by Conductix-Wampfler hold their own wherever energy, data and media have to cover the most diverse distances within a short amount of time - in all directions, fast and safe.



Festoon systems

It's hard to imagine Conductix-Wampfler cable trolleys not being used in virtually every industrial application. They're reliable and robust and available in an enormous variety of dimensions and designs.

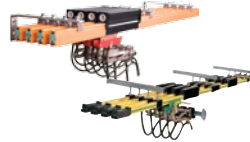

Conductor rails

Whether they're enclosed conductor rails or expandable single-pole systems, the proven conductor rails by Conductix-Wampfler reliably move people and material.

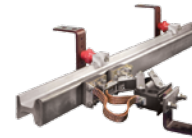

Non-insulated conductor rails

Extremely robust, non-insulated conductor rails with copper heads or stainless steel surfaces provide the ideal basis for rough applications, for example in steel mills or shipyards.



Energy guiding chains

The "Jack of all trades" when it comes to transferring energy, data, air and fluid hoses. With their wide range, these energy guiding chains are the ideal solution for many industrial applications.



Slip ring assemblies

Whenever things are really "moving in circles", the proven slip ring assemblies by Conductix-Wampfler ensure the flawless transfer of energy and data. Here, everything revolves around flexibility and reliability!



Inductive Power Transfer IPT®

The no-contact system for transferring energy and data. For all tasks that depend on high speeds and absolute resistance to wear.



Reels, retractors and balancers

Whether for hoses or cables, as classical reels or high-precision positioning aids for tools, our range of reels and spring balancers take the load off your shoulders.



Jib boom

Complete with tool transporters, reels, or an entire media supply system - here, safety and flexibility are key to the completion of difficult tasks.

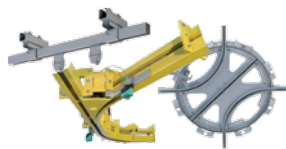

Conveyor systems

Whether manual, semiautomatic or with Power & Free - flexibility is achieved with full customization concerning layout and location.

www.conductix.us

USA

10102 F Street
Omaha, NE 68127

Customer Support

Phone (+1) 800 521 4888

Fax (+1) 800 780 8329

Phone (+1) 402 339 9300

Fax (+1) 402 339 9627

info.us@conductix.com

CANADA

175 Blvd JF Kennedy
St. Jerome, QC J7Y 4B5

Customer Support

Phone (+1) 800 667 2487

Fax (+1) 800 442 9817

Phone (+1) 450 565 9900

Fax (+1) 450 432 6985

info.ca@conductix.com

MEXICO

Calle Treviño 983-C
Zona Centro
Apodaca, NL México 66600

Customer Support

Phone (+52) 81 1090 9519

(+52) 81 1090 9025

(+52) 81 1090 9013

Fax (+52) 81 1090 9014

info.mx@conductix.com

BRAZIL

Rua Luiz Pionti, LT 05, QD.
L - Vila Progresso
Itu, São Paulo, Brasil
CEP: 13.313-534

Customer Support

Phone (+55) 11 4813 7330

Fax (+55) 11 4813 7330

info.br@conductix.com

Contact us for our Global Sales Offices

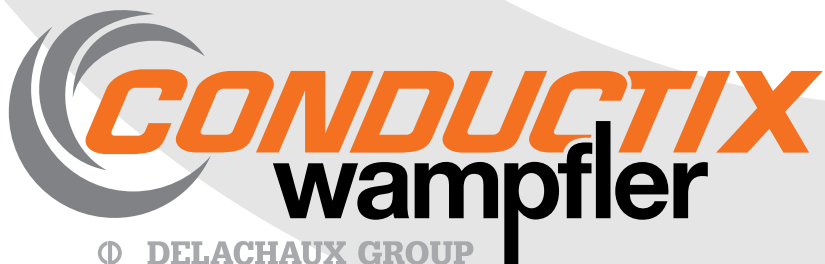

KAT0831-0001e-US

