



ENCLOSED CONDUCTOR SYSTEM - MKH



ENCLOSED CONDUCTOR SYSTEM MKH

CONTENTS

Technical data	4-5	Maintenance sections	25
Technical data & standard sections	6-7	Conductor dead sections	26
Types & order numbers	8-9	Anti-condensation sections	27
Curves & sealing strips	10	Expansion sections	28
Hangers & end sections	11	APOS Positioning System	29
Brackets	12	Collectors	30-32
Jointing material & end feeds	13	Tow arms	33
Line feeds	14-17	Flat copper & cable glands	34
Heating	18-19	Assembling tools	35
Contact sections, turntables & switches	20	Example for ordering	36
Entry funnel	21	Spare parts	37
Transfer guides	22-23	Questionnaire	38
Removal sections	24	Service & Support	39

SYSTEM OVERVIEW

VAHLE's MKH is a fully enclosed conductor bar solution for indoor and outdoor use. The insulated "honey comb" design of the housing can accommodate various copper profiles depending on amperage requirements. Three models of MKH exist with characteristics suitable to many different applications.

TYPE MKHD: 6 to 10 copper conductors version with continuous copper strips. Rated at 40 to 160 amps. Copper strips supplied as separate coils to be installed on site.

TYPE MKHF: 6 to 8 conductor version with pre-installed copper conductors and spring loaded joint connectors. Supplied in 4 meter lengths. Can be cut to size as required. Rated at 40 to 100 amps.

TYPE MKHS: 6 to 8 conductor version with pre-installed copper conductors and bolted joint connectors. Supplied in 4 meter lengths. Can be cut to size as required. Rated at 40 to 200 amps.

MKH's main features include a compact design, resistance to corrosion, high user safety, and ease of installation. MKH complies with VDE,

European and international standards, as well as accident prevention regulations. It is protected to IP 23 standards and UL approved.

MKH benefits from a variety of VAHLE exclusive accessories that allow it to adapt to any application. Accessories include sealing strip, an internal heating system and specialty sections (see respective pages). With the optional sealing strip installed, MKH is protected to IP 24 standards and EN 605296 (0470, part) regulation.

Important safety information: If there is the possibility to touch live parts by hand, i.e. collectors that might leave the conductor bar during operation, provide safety barrier and/or disconnect mains. Collectors are safe against touch only when fully entered into the conductor system.

This is valid only for a supply voltage exceeding 24 V AC or 60 V DC. Low voltages of max. 50 V AC or 120 V DC are allowable only if the conductor system is used as a control line (type "SS"). Refer to regulation SELV or PELV (also DIN VDE 0100 410). A ground conductor is required for higher voltages.



TECHNICAL DATA

APPLICATIONS

Provides mobile power feeding of overhead cranes, monorail systems, electric hoists, electric power tools, machine tools, automated storage and retrieval systems, assembly and test lines, hangar doors, studio & station lighting systems and many others.

APPROVALS: UL approved

HOUSING

- Color grey, plastic housing for 6 to 10 conductors
- Standard section 4 meters. Shorter lengths are available by request
- The ground conductor is identified by international color code
- Phase reversing prevented by housing "saftey web"
- Higher number of conductors possible by combination of several conductor systems

COUPLINGS:

- Via spring loaded or bolted joints, protected by plastic joint caps
- Type MKHD uses continuous copper coils

FEED SETS

- Through line feeds or end feeds
- When selecting the "overload" protection devices, selection has to be made according to DIN VDE 0100 part 530

END SECTIONS:

- Type MKHD requires "end section" with end cap installed
- Standard end caps available for types MKHF & MKHS

HANGERS

Sliding and fixpoint hangers required for installation. Hanger brackets available on request (page 11). Maximum support distance within the following ambient temperatures:

- Indoor systems and covered outdoor systems < 35°C: 2.00 meters
- Indoor and uncovered outdoor systems > 35°C: 1.33 meters
- Cold and frozen storage < 0°C: 1.33 meters

EXPANSION DURING TEMPERATURE FLUCTUATION

For systems requiring expansion compensation, expansion sections are available for MKH that do not cause electrical interruption.

See page 28.

ANTI-CONDENSATION SECTIONS

For systems installed in multiple temperature zones, i.e. warm to cold or cold to warm, anti condensation sections are available to prevent buildup of moisture within conductor bar. See page 27.

CONTACT SECTIONS, TURNABLES, SWITCHES

Conductor systems with entry funnels or transfer guides see pages 20,21.

SECTIONALIZING

Conductor dead sections are electrical interrupts of the conductor. Under normal operating conditions a cross over with collectors to switch the voltage off or on is only allowed with low power ratings (control current). The conductors can be seperated through air gaps (5 mm) or insulating pieces (35 mm). With the air gap the collector carbon bridges the gap, e.g. for mains. The insulating piece is longer than the carbon and each conductor rail section can be separated electrically, e.g. for control. Double isolating sections are recommended to guarantee safely separated conductor sections as per EN 60204.

COLLECTORS

The current collectors are made of reinforced polyester fiberglass, for high strength and light weight. Spring loaded carbon brushes maintain uniform contact. Connecting cables and hinged or flexible towing arms included. The length of the connecting cable may not exceed 3m if the added overload protection device is not designed for the load capacity of this cable. Refer also to regulation VDE 0100, part 430 and EN 60204 32. (Note: This occurs often with several collectors per system.)

WITH FOLLOWING SYSTEM REQUIREMENTS DOUBLE COLLECTORS HAVE TO BE USED:

- As proper measure to fulfill the continuity of the ground conductor system via carbon brushes. Refer to regulation EN 60204 1 2007 06 and EN 60204 32 2009 03
- Transfers with switches and turntables
- Low voltages, frequency controlled drives
- Transmission of data and/or emergency stop signals
- High electrical loads

The length of the collector cable may not exceed 3m if the added overcurrent protection device is not designed for the load capacity of this cable. Please refer also to regulations VDE 0100, part 430 and EN 60204 32.

Please note: For use in galvanizing and pickling plants, under aggressive conditions and low voltage applications, we would appreciate receiving detailed information, especially of the environmental conditions.

For quotations and order processing including Powerail systems with curves, dead sections, turntables, switches, etc. we require your drawing or sketches. Please use our questionnaire, page 38.

In case of special environmental conditions, the PVC housing can be equipped with stainless steel conductors (contact us for more details). Please send detailed information. For low voltage applications, please consult our factory.

TECHNICAL DATA

ELECTRICAL PROPERTIES

Max. continuous current	Nominal voltage (UL)	Dielectric strength	Spec. resistance	Surface resistance	Leakage resistance
200A (with 80% duty cycle)	690V (600V)	IEC 60243 30 40 KV/mm	IEC 60093 $5 \times 10^{15} \Omega/\text{cm}$	IEC 60093 $10^{13}\Omega$	EN 60112 CTI 400 2.7

MECHANICAL PROPERTIES

Flexible strength	Tensile strength	Temperature range (ambient)	Combustibility	Resistance to chemicals (at + 45 °C)
75 N/mm ² ± 10 %	40 N/mm ² ± 10	-30 °C to + 60 °C	Flame retardant DIN 41 02 Class B 1; self extinguishing	Gasoline, Mineral Oil, Grease, Sulphuric acid 50 %, Caustic soda 25 % and 50 % Hydro chloric acid, concentrated

Ambient temperature °C	35 °C	40 °C	45 °C	50 °C	55 °C	60 °C
Correction factor f_T Standard shrouding	1	0.95	0.89	0.84	0.77	0.71

VOLTAGE DROP FOR THE CONDUCTOR

For three phase current
$\Delta U = \sqrt{3} \cdot I \cdot I_A \cdot Z$
For alternating current
$\Delta U = 2 \cdot I \cdot I_A \cdot Z$
For direct current
$\Delta U = 2 \cdot I \cdot I_A \cdot R$

Z = impedance [Ω/km]

R = resistance [Ω/km]

I = feed length [km]

I_A = inrush current of installation in amperes

PERMISSIBLE CONTINUOUS CURRENT OF THE CONDUCTOR

$$I_{Dzul.U.T} = I_{zul} \cdot x \cdot f_T[A] \text{ with } I_{Dzul.U.T} > I_{DA}$$

I_{zul} = Permissible continuous current of the conductor at 35 °C (catalogue value)
(A)

f_T = Correction factor

TECHNICAL DATA - MKH(F/S)

CROSS SECTIONS⁽¹⁾

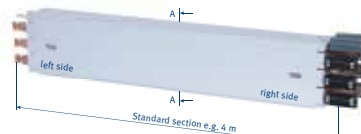
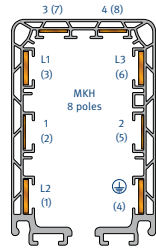
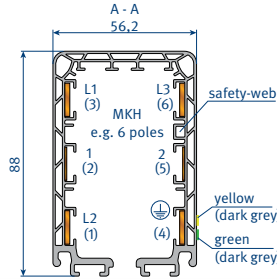

Type MKHF with plug in joints, factory assembled

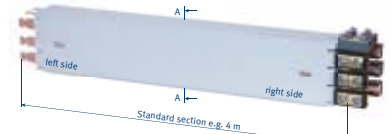

Type MKHS with bolted joints, factory assembled

Type ⁽²⁾ HS with PE SS without PE	No. of conductors	Copper cross section mm ²				Ampere rating with 35 °C in A, L1, L2, L3 ⁽⁵⁾			Nominal Voltage V ⁽⁴⁾	Impedance at 50 HZ 20 °C Ω/1000 m		Resistance at 20 °C Ω/1000 m		Leakage distance (mm)
		Phase L1, L2, L3		Control line		60% DC	80% DC	100% DC		Phase L1, L2, L3		Phase L1, L2, L3		
MKH 6/63 HS	6	3x10	10	2x10		81	70	63	690	1.731	1.731	1.717	1.717	30
MKH 6/63 SS	6			6x10		81	70	63	690	1.731		1.717		30
MKH 6/80 HS	6	3x17	17	2x10		103	89	80	690	1.078	1.078	1.057	1.057	30
MKH 6/100 HS	6	3x26	26	2x10		129	112	100	690	0.717	0.717	0.687	0.687	30
MKH 6/140 HS ⁽³⁾	6	3x33	26	2x10		161	140	125	690	0.586	0.717	0.549	0.687	30
MKH 6/160 HS ⁽³⁾	6	3x42	26	2x10		184	160	143	690	0.473	0.717	0.429	0.687	30
MKH 6/200 HS ⁽³⁾	6	3x51	26	2x10		231	200	179	690	0.393	0.717	0.344	0.687	30
MKH 7/63 HS	7	3x10	10	2x10	1x11	81	70	63	690	1.731	1.731	1.717	1.717	30
MKH 7/63 SS	7			6x10	1x11	81	70	63	690	1.731		1.717		30
MKH 7/80 HS	7	3x17	17	2x10	1x11	103	89	80	690	1.078	1.078	1.057	1.057	30
MKH 7/100 HS	7	3x26	26	2x10	1x11	129	112	100	690	0.717	0.717	0.687	0.687	30
MKH 7/140 HS ⁽³⁾	7	3x33	26	2x10	1x11	161	140	125	690	0.586	0.717	0.549	0.687	30
MKH 7/160 HS ⁽³⁾	7	3x42	26	2x10	1x11	184	160	143	690	0.473	0.717	0.429	0.687	30
MKH 7/200 HS ⁽³⁾	7	3x51	26	2x10	1x11	231	200	179	690	0.393	0.717	0.344	0.687	30
MKH 8/63 HS	8	3x10	10	2x10	2x11	81	70	63	690	1.731	1.731	1.717	1.717	30
MKH 8/63 SS	8			6x10	2x11	81	70	63	690	1.731		1.717		30
MKH 8/80 HS	8	3x17	17	2x10	2x11	103	89	80	690	1.078	1.078	1.057	1.057	30
MKH 8/100 HS	8	3x26	26	2x10	2x11	129	112	100	690	0.717	0.717	0.687	0.687	30
MKH 8/140 HS ⁽³⁾	8	3x33	26	2x10	2x11	161	140	125	690	0.586	0.717	0.549	0.687	30
MKH 8/160 HS ⁽³⁾	8	3x42	26	2x10	2x11	184	160	143	690	0.473	0.717	0.429	0.687	30
MKH 8/200 HS ⁽³⁾	8	3x51	26	2x10	2x11	231	200	179	690	0.393	0.717	0.344	0.687	30

(1) Numbers in paranthesis apply to control line

(2) Complete types e.g. MKHS 7/63 HS for 7 poles with bolted joints

(3) Require MKHS with bolted joints

(4) Nominal voltage UL = 600V



(5) Power consumption UL on request

TECHNICAL DATA - MKHD

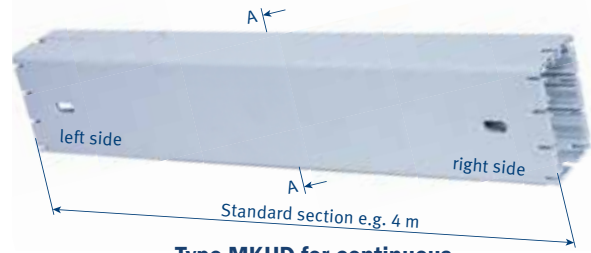
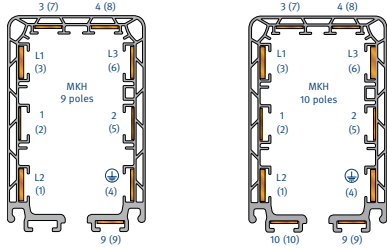
CROSS SECTIONS⁽¹⁾



Type MKHD for continuous copper strips

Type HS with PE SS without PE	No. of conductors	Copper cross section mm ²		Ampere rating with 35 °C in A, L1, L2, L3 ⁽³⁾			Nominal Voltage V ⁽²⁾	Impedance at 50 HZ 20 °C Ω/1000 m		Resistance at 20 °C Ω/1000 m		Leakage distance (mm)		
		Phase L1, L2, L3		Control line	60% DC	80% DC		100% DC	Phase L1, L2, L3		Phase L1, L2, L3			
MKHD 9/63 HS	9	3x10	10	2x10	3x11	81	70	63	690	1.731	1.731	1.717	1.717	30
MKHD 9/63 SS	9			6x10	3x11	81	70	63	690	1.731		1.717		30
MKHD 9/80 HS	9	3x17	17	2x10	3x11	103	89	80	690	1.078	1.078	1.057	1.057	30
MKHD 9/100 HS	9	3x26	26	2x10	3x11	129	112	100	690	0.717	0.717	0.687	0.687	30
MKHD 9/140 HS	9	3x33	26	2x10	3x11	161	140	125	690	0.586	0.717	0.549	0.687	30
MKHD 9/160 HS	9	3x42	26	2x10	3x11	184	160	143	690	0.473	0.717	0.429	0.687	30
MKHD 10/63 HS	10	3x10	10	2x10	4x11	81	70	63	690	1.731	1.731	1.717	1.717	30
MKHD 10/63 SS	10			6x10	4x11	81	70	63	690	1.731		1.717		30
MKHD 10/63 HS	10	3x17	17	2x10	4x11	103	89	80	690	1.078	1.078	1.057	1.057	30
MKHD 10/100 HS	10	3x26	26	2x10	4x11	129	112	100	690	0.717	0.717	0.687	0.687	30
MKHD 10/140 HS	10	3x33	26	2x10	4x11	161	140	125	690	0.586	0.717	0.549	0.687	30
MKHD 10/160 HS	10	3x42	26	2x10	4x11	184	160	143	690	0.473	0.717	0.429	0.687	30

(1) Numbers in parenthesis apply to control line

(2) Nominal voltage UL = 600V

(3) Power consumption UL on request

TYPES & ORDER NUMBERS

TYPE MKHD

Continuous copper strips – to be drawn in during installation.

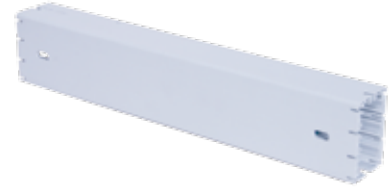

Type	Weight kg/m (lbs)	Order No. ⁽¹⁾
MKHD HS	1.052 (2.3)	262 504
MKHD SS ⁽²⁾	1.052 (2.3)	262 514

TYPE MKHF

Factory assembled copper strips and plug in joints (40 100A)



Type	Weight kg/m (lbs)	Order No. ⁽¹⁾
MKHF 6/63 HS	1.638 (3.6)	263 204
MKHF 6/63 SS ⁽²⁾	1.638 (3.6)	263 224
MKHF 6/80 HS	1.839 (4.1)	263 214
MKHF 6/100 HS	2.176 (4.8)	262 054
MKHF 7/63 HS	1.748 (3.9)	263 234
MKHF 7/63 SS ⁽²⁾	1.748 (3.9)	263 254
MKHF 7/80 HS	1.949 (4.3)	263 244
MKHF 7/100 HS	2.277 (5.0)	262 094
MKHF 8/63 HS	1.858 (4.1)	263 264
MKHF 8/63 SS ⁽²⁾	1.858 (4.1)	263 284
MKHF 8/80 HS	2.059 (4.5)	263 274
MKHF 8/100 HS	2.387 (5.3)	262 134

(1) Last number of the order specifies the section length in meters. Standard section length is 4 meters.

For shorter lengths, suffix the order number with 1, 2 or 3.

(2) Type SS designates no ground marking. For control line only.

TYPES & ORDER NUMBERS

TYPE MKHS

Factory assembled copper strips and bolted joints (40 200A)



Type	Weight kg/m (lbs)	Order No. ⁽¹⁾
MKHS 6/63 HS	1.824 (4.0)	263 294
MKHS 6 63 SS ⁽²⁾	1.824 (4.0)	263 314
MKHS 6/80 HS	1.950 (4.3)	263 304
MKHS 6/100 HS	2.353 (5.1)	262 304
MKHS 6/140 HS	2.530 (5.6)	262 204
MKHS 6/160 HS	2.773 (6.1)	262 214
MKHS 6/200 HS	3.019 (6.7)	262 224
MKHS 7/63 HS	1.961 (4.3)	262 324
MKHS 7/63 SS ⁽²⁾	1.961 (4.3)	262 344
MKHS 7/80 HS	2.087 (4.6)	263 334
MKHS 7/100 HS	2.490 (5.5)	262 274
MKHS 7/140 HS	2.667 (5.9)	262 284
MKHS 7/160 HS	2.910 (6.4)	262 294
MKHS 7/200 HS	3.156 (7.0)	262 304
MKHS 8/63 HS	2.098 (4.6)	263 354
MKHS 8/63 SS ⁽²⁾	2.098 (4.6)	263 374
MKHS 8/80 HS	2.224 (4.9)	263 364
MKHS 8/100 HS	2.627 (5.8)	262 344
MKHS 8/140 HS	2.804 (6.2)	262 354
MKHS 8/160 HS	3.047 (6.7)	262 364
MKHS 8/200 HS	3.293 (7.3)	262 374

(1) Last number of the order specifies the section length in meters. Standard section length is 4 meters.

For shorter lengths, suffix the order number with 1, 2 or 3.

(2) Type SS designates no ground marking. For control line only.

CURVES & SEALING STRIPS

CURVES

Factory bending of MKH conductor bar is possible. Minimum horizontal bending radius is 1000 mm. Maximum length of curved section is 3600 mm. Maximum angle is 120°. Vertical curves available upon request. Consult factory for details. Conductor bar safety web is installed facing site track.

SI = Horizontal curve, safety web inside

SA = Horizontal curve, safety web outside

VRO = Vertical curve, safety web outside (facing upwards)

VRU = Vertical curve, safety web inside (facing downwards)

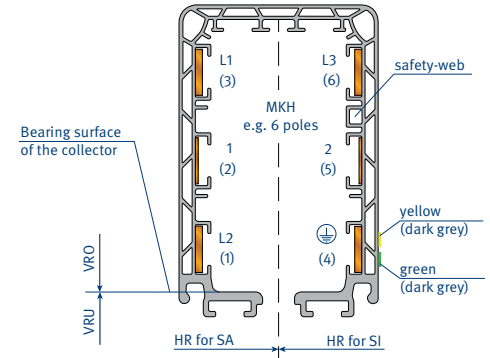

SEALING STRIP & ACCESSORIES

Sealing strip is sold in 10 meter increments. Max continuous length is 40M. Sealing strip works in pairs and must be ordered in doubles, i.e. 40 meter system length requires 80 meter sealing strip. Systems with 9 and 10 poles are not available with sealing strip.

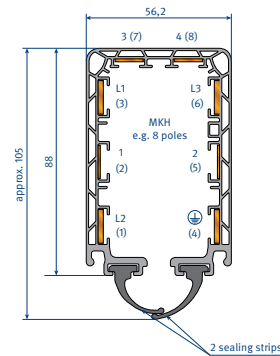

SEALING STRIP & ACCESSORIES



Type	Order No.
Sealing strip (sold in 10 M increments) ⁽¹⁾	600 551
Fixing clamp (1 per end)	236 105
Joint coupling (2 per joint)	258 300
Installation tool for sealing strip	234 552
Collector plate	236 625

(1) Strip sold in 10m increments. Max continuous length is 40m.

Strip for MKH works in pairs. Example: 40m system length requires 80m sealing strip.

HANGERS & END SECTIONS

SLIDING HANGER

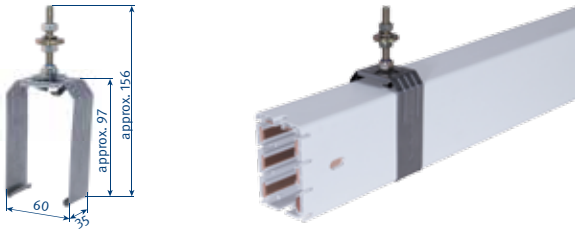

Type	Weight kg/m (lbs)	Order No.
MGH	0.134 (0.3)	262 000
MGH/K ⁽¹⁾	0.134 (0.3)	262 003

FIXPOINT HANGER

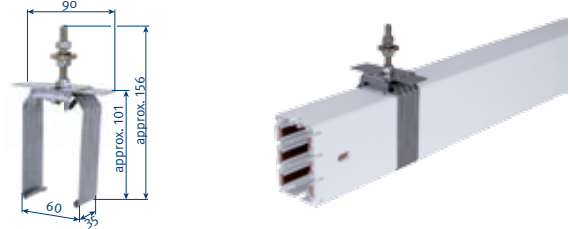

Type	Weight kg/m (lbs)	Order No.
MFH	0.182 (0.4)	262 001
MFH/K ⁽¹⁾	0.182 (0.4)	262 002

END SECTION (MKHD)

0.3m long

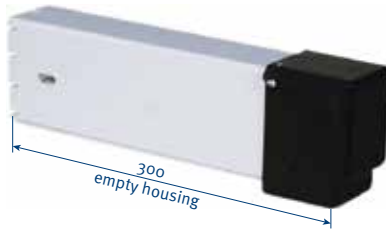

Type	Weight kg/m (lbs)	Orientation	Order No.
MHED/L	0.401 (0.9)	Left	262 537
MHED/R	0.401 (0.9)	Right	262 536

END CAP (MKHF/MKHS)

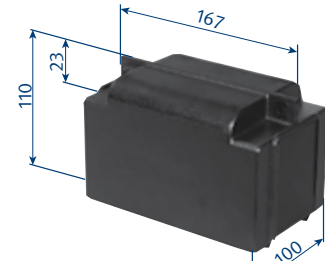

Type	Weight kg/m (lbs)	Orientation	Order No.
MSES	0.308 (0.7)	Left & right	235 141

(1) Stainless steel

BRACKETS

POSITION OF THE FIXING CLAW FOR D=6-15MM

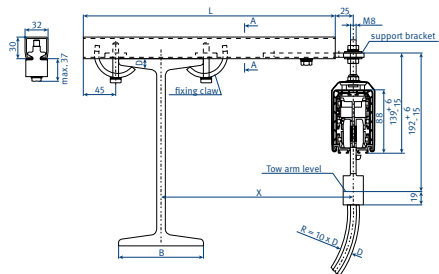

POSITION OF THE FIXING CLAW FOR D=15 -25MM

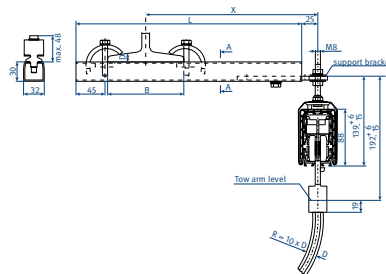

ARRANGEMENT EHK WITH SMALL FIXING CLAW

Attention: Make sure that hoist wheels have enough clearance.

Use small claw if necessary.

rail of EHK is identical to type S1, Cat. 8a

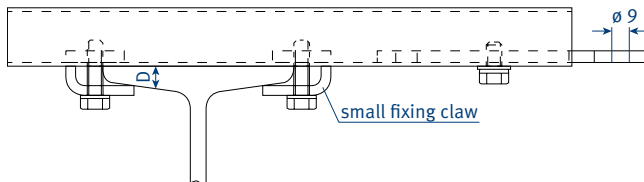

Type ⁽¹⁾	X mm	L mm	B max mm	Weight kg (lbs)	Order No.	
					Standard version	with small fixing claw ⁽¹⁾
EHK250	250	350	170	1.080 (2.4)	251 600	251 720
EHK300	300	400	170	1.128 (2.5)	251 610	251 730
EHK400	400	500	170	1.266 (2.8)	251 620	251 740
EHK500	500	600	170	1.394 (3.1)	251 630	251 750
EHK600	600	700	170	1.561 (3.4)	251 640	251 760
EHK700	700	800	170	1.761 (3.9)	251 650	251 770
EHK750	750	850	170	1.782 (3.9)	251 660	251 780
EHK800	800	900	170	1.936 (4.3)	251 670	251 790

(1) e.g. EHK250 KS12 → Order No. 251720 12 for fixing claw with D=12mm

Select next larger size bracket when your beam dimension B is more than 170 mm.

JOINTING MATERIAL & END FEEDS

JOINT CAP, SELF LOCKING (MKHD)

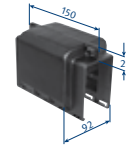

Type	Weight kg (lbs)	Order No.
MVMD	0.160 (0.4)	234 678

JOINT CAP, SELF LOCKING (MKHF/S)

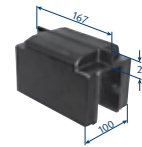

Type	Weight kg (lbs)	Order No.
MVMS	0.274 (0.6)	234 585

END FEED (MKHD)

- End feed comes loose without powerail section.
- It can be mounted at the left or right hand side.
- Electrical connection with customer supplied cable shoes to M6 terminals.

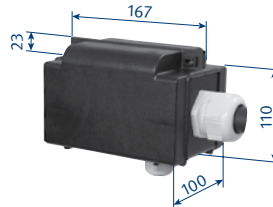

6-8 poles

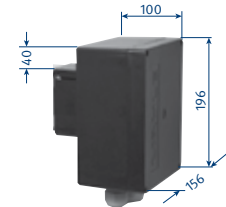

9-10 poles

Type	Weight kg (lbs)	Cable Gland (Dimensions see p.34)	Order No.
MKED 6 8/63-80 HS	0.515 (1.1)	M 25 and M 40	235 152
MKED 9 10/63-80 HS	1.071 (2.4)	M 25 and M 40	262 538
MKED 6 8/63 SS ⁽¹⁾	0.470 (1.0)	M 25	235 157
MKED 9 10/63 SS ⁽¹⁾	1.020 (2.2)	M 25	262 539

END FEED (MKHF/MKHS)

- End feed comes loose without powerail section.
- It can be mounted at the left or right hand side.
- Electrical connection with customer supplied cable shoes to M6 terminals.

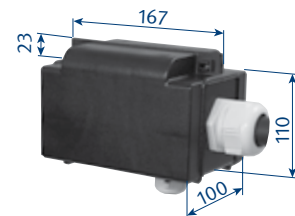

Type	Weight kg (lbs)	Cable gland (Dimensions see p.34)	Order No.
MKES 6 8/63-80 HS	0.492 (1.1)	M 25 and M 40	235 230
MKES 6 8/63 SS ⁽¹⁾	0.446 (1.0)	M 25	235 233

(1) No ground

LINE FEEDS - MKHD

Electrical connection with customer supplied cable shoes to M8 terminals.

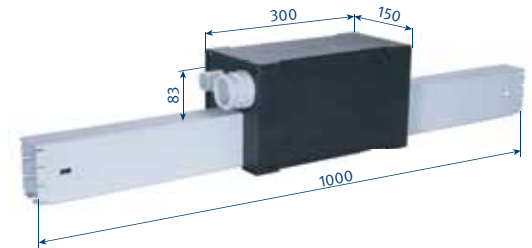

Photo shows MHGD

Type	Weight kg (lbs)	Cable gland (Dimensions see p.34)	Order No.
MHGD 6/63-100 HS	2.445	M 50 and M 25	262 545
MHGD 7/63-100 HS	2.530	M 50 and M 25	262 546
MHGD 8/63-100 HS	2.615	M 50 and M 25	262 547
MHGD 9/63-100 HS	2.654	M 50 and M 25	262 548
MHGD 10/63-100 HS	2.693	M 50 and M 25	262 549
MHGD 6/140-160 HS	2.431	M 50 and M 25	262 550
MHGD 7/140-160 HS	2.516	M 50 and M 25	262 551
MHGD 8/140-160 HS	2.601	M 50 and M 25	262 552
MHGD 9/140-160 HS	2.640	M 50 and M 25	262 553
MHGD 10/140-160 HS	2.679	M 50 and M 25	262 554
MHGD 6/63 SS ⁽¹⁾	2.385	M 25	262 540
MHGD 7/63 SS ⁽¹⁾	2.460	M 25	262 541
MHGD 8/63 SS ⁽¹⁾	2.545	M 25	262 542
MHGD 9/63 SS ⁽¹⁾	2.584	M 25	262 543
MHGD 10/63 SS ⁽¹⁾	2.623	M 25	262 544

(1) No ground

LINE FEEDS - MKHD

Electrical connection with customer supplied cable shoes to M8 terminals.

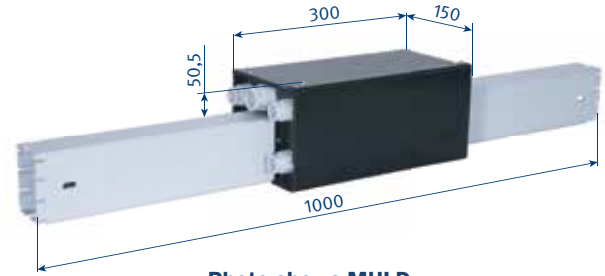

Photo shows MHL D

Type	Weight kg (lbs)	Cable gland (Dimensions see p. 34)	Order No.
MHL D 6/63-100 HS	2.565 (5.7)	M 25 for L1, L2, L3 M 25 for 1 4 M 20 for PE, 9/10	262 560
MHL D 7/63-100 HS	2.651 (5.8)		262 561
MHL D 8/63-100 HS	2.737 (6.0)		262 562
MHL D 9/63-100 HS	2.745 (6.1)		262 563
MHL D 10/63-100 HS	2.749 (6.1)		262 564
MHL D 6/140-160 HS	2.553 (5.6)	M 25 for L1, L2, L3 M 25 for 1 4 M 20 for PE, 9/10	262 565
MHL D 7/140-160 HS	2.639 (5.8)		262 566
MHL D 8/140-160 HS	2.725 (6.0)		262 567
MHL D 9/140-160 HS	2.733 (6.0)		262 568
MHL D 10/140-160 HS	2.737 (6.0)		262 569
MHL D 6/63 SS ⁽¹⁾	2.517 (5.5)	1 x M 25	262 555
MHL D 7/63 SS ⁽¹⁾	2.593 (5.7)		262 556
MHL D 8/63 SS ⁽¹⁾	2.679 (5.9)		262 557
MHL D 9/63 SS ⁽¹⁾	2.687 (5.9)	2 x M 25	262 558
MHL D 10/63 SS ⁽¹⁾	2.691 (5.9)		262 559

⁽¹⁾ No ground

LINE FEEDS - MKHF/S

Electrical connection with customer supplied cable shoes to M8 terminals.

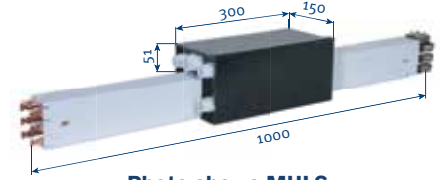

Photo shows MHLF

Type	Weight kg (lbs)	Cable gland (Dimensions see p. 34)	Order No.
MHLF 6/63 HS	3.170 (7.0)	M 25 for L1, L2, L3 M 25 for 1 4 M 20 for PE	263 235
MHLF 7/63 HS	3.364 (7.4)		263 236
MHLF 8/63 HS	3.558 (7.8)		263 237
MHLF 6/80 HS	3.402 (7.5)		263 238
MHLF 7/80 HS	3.596 (7.9)		263 239
MHLF 8/80 HS	3.790 (8.4)		263 240
MHLF 6/100 HS	3.730 (8.2)		262 486
MHLF 7/100 HS	3.924 (8.7)		262 487
MHLF 8/100 HS	4.118 (9.1)		262 488
MHLF 6/63 SS	3.075 (6.8)		M 25
MHLF 7/63 SS	3.269 (7.2)	263 246	
MHLF 8/63 SS	3.463 (7.6)	263 247	

Type	Weight kg (lbs)	Cable gland (Dimensions see p. 34)	Order No.
MHLS 6/63 HS	3.356 (7.4)	M 25 for L1, L2, L3 M 25 for 1 4 M 20 for PE	263 248
MHLS 7/63 HS	3.577 (7.9)		263 249
MHLS 8/63 HS	3.798 (8.4)		263 250
MHLS 6/80 HS	3.588 (7.9)		263 255
MHLS 7/80 HS	3.809 (8.4)		263 256
MHLS 8/80 HS	4.030 (8.9)		263 257
MHLS 6/100 HS	3.916 (8.6)		262 524
MHLS 7/100 HS	4.137 (9.1)		262 525
MHLS 8/100 HS	4.358 (9.6)		262 526
MHLS 6/140 HS	4.081 (9.0)		M 25 for PE, L1, L2, L3 M 25 for 1 4
MHLS 7/140 HS	4.302 (9.5)	262 528	
MHLS 8/140 HS	4.523 (10.0)	262 529	
MHLS 6/160 HS	4.324 (9.5)	262 530	
MHLS 7/160 HS	4.545 (10.0)	262 531	
MHLS 8/160 HS	4.766 (10.5)	262 532	
MHLS 6/200 HS	4.570 (10.1)	262 533	
MHLS 7/200 HS	4.791 (10.6)	262 534	
MHLS 8/200 HS	5.012 (11.0)	262 535	
MHLS 6/63 SS	3.256 (7.2)	M 25	263 258
MHLS 7/63 SS	3.477 (7.7)		263 259
MHLS 8/63 SS	3.698 (8.2)		263 260

LINE FEEDS - MKHF/S

Electrical connection with customer supplied cable shoes to M8 terminals.

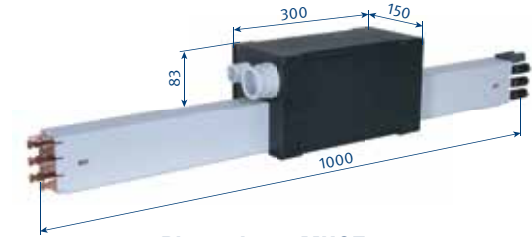

Photo shows MHGF

Type	Weight kg (lbs)	Cable gland (Dimensions see p. 34)	Order No.
MHGF 6/63 HS	3.056 (6.7)	M 50 and M 25	263 205
MHGF 7/63 HS	3.250 (7.2)	M 50 and M 25	263 206
MHGF 8/63 HS	3.444 (7.6)	M 50 and M 25	263 207
MHGF 6/80 HS	3.288 (7.2)	M 50 and M 25	263 208
MHGF 7/80 HS	3.482 (7.7)	M 50 and M 25	263 209
MHGF 8/80 HS	3.676 (8.1)	M 50 and M 25	263 210
MHGF 6/100 HS	3.616 (8.0)	M 50 and M 25	262 498
MHGF 7/100 HS	3.810 (8.4)	M 50 and M 25	262 499
MHGF 8/100 HS	4.004 (8.8)	M 50 and M 25	262 500
MHGF 6/63 SS	2.948 (6.5)	M 25	263 215
MHGF 7/63 SS	3.142 (6.9)	M 25	263 216
MHGF 8/63 SS	3.336 (7.4)	M 25	263 217

Type	Weight kg (lbs)	Cable gland (Dimensions see p. 34)	Order No.
MHGS 6/63 HS	3.242 (7.1)	M 50 and M 25	263 218
MHGS 7/63 HS	3.463 (7.6)	M 50 and M 25	263 219
MHGS 8/63 HS	3.684 (8.1)	M 50 and M 25	263 220
MHGS 6/80 HS	3.474 (7.7)	M 50 and M 25	263 225
MHGS 7/80 HS	3.695 (8.1)	M 50 and M 25	263 226
MHGS 8/80 HS	3.916 (8.6)	M 50 and M 25	263 227
MHGS 6/100 HS	3.802 (8.4)	M 50 and M 25	262 456
MHGS 7/100 HS	4.023 (8.7)	M 50 and M 25	262 457
MHGS 8/100 HS	4.244 (9.4)	M 50 and M 25	262 458
MHGS 6/140 HS	3.965 (8.7)	M 50 and M 25	262 459
MHGS 7/140 HS	4.186 (9.2)	M 50 and M 25	262 460
MHGS 8/140 HS	4.407 (9.7)	M 50 and M 25	262 461
MHGS 6/160 HS	4.208 (9.3)	M 50 and M 25	262 462
MHGS 7/160 HS	4.429 (9.8)	M 50 and M 25	262 463
MHGS 8/160 HS	4.650 (10.3)	M 50 and M 25	262 464
MHGS 6/200 HS	4.454 (9.8)	M 50 and M 25	262 465
MHGS 7/200 HS	4.675 (10.3)	M 50 and M 25	262 466
MHGS 8/200 HS	4.896 (10.8)	M 50 and M 25	262 467
MHGS 6/63 SS	3.135 (6.9)	M 25	263 228
MHGS 7/63 SS	3.356 (7.4)	M 25	263 229
MHGS 8/63 SS	3.577 (7.9)	M 25	263 230

HEATING

HEATING CABLE

Type	Resistance ⁽¹⁾	Order No.
HL 0.10 EYCEX 5203 PTFE 260 750	0.10 Ω/m	196 381
HL 0.15 EYCEX 5203 PTFE 260 750	0.15 Ω/m	196 382
HL 0.20 EYCEX 5203 PTFE 260 750	0.20 Ω/m	196 383
HL 0.32 EYCEX 5203 PTFE 260 750	0.32 Ω/m	196 384
HL 0.38 EYCEX 5203 PTFE 260 750	0.38 Ω/m	196 385
HL 0.48 EYCEX 5203 PTFE 260 750	0.48 Ω/m	196 386
HL 0.60 EYCEX 5203 PTFE 260 750	0.60 Ω/m	196 387
HL 0.81 EYCEX 5203 PTFE 260 750	0.81 Ω/m	196 389
HL 1.00 EYCEX 5203 PTFE 260 750	1.00 Ω/m	196 390
HL 1.44 EYCEX 5203 PTFE 260 750	1.44 Ω/m	196 391
HL 2.00 EYCEX 5203 PTFE 260 750	2.00 Ω/m	196 392
HL 3.00 EYCEX 5203 PTFE 260 750	3.00 Ω/m	196 393
HL 4.00 EYCEX 5203 PTFE 260 750	4.00 Ω/m	196 394
HL 4.40 EYCEX 5203 PTFE 260 750	4.40 Ω/m	196 395
HL 5.16 EYCEX 5203 PTFE 260 750	5.16 Ω/m	196 396
HL 5.60 EYCEX 5203 PTFE 260 750	5.60 Ω/m	196 397

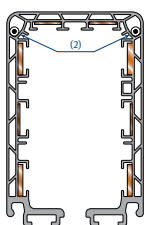

We recommend a heating system for uncovered outdoor installations in cold environments and installations in humid plants. The heating consists of arranging two heating cables as per drawing.

Attention: Switch on heating system below + 5 °C ambient temperature.

The type of heating cable has to be calculated: heat output per heating cable between 20-25 W/m. Depending on system length, several heating sections may be required. Contact factory for calculations and requirements.

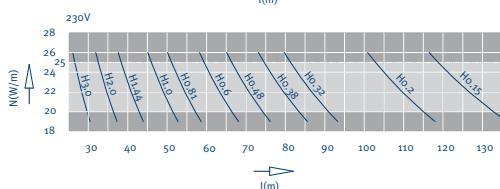
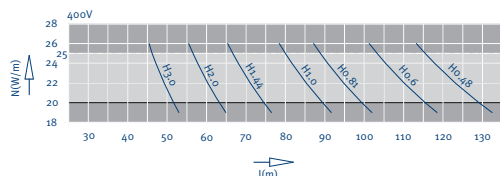

$$\text{Heating capacity [Watt/m]: } N' = \frac{U^2}{R \cdot L^2}$$

U = Supply voltage [Volt]

R = Resistance of heating cable [Ohm/m]

L = Length of heating section [m]

(1) Deviations ± 2.5 %

(2) Arrangement of heating cable

HEATING

SWITCH EXAMPLES (DEPENDENT ON INSTALLATION SITUATION)

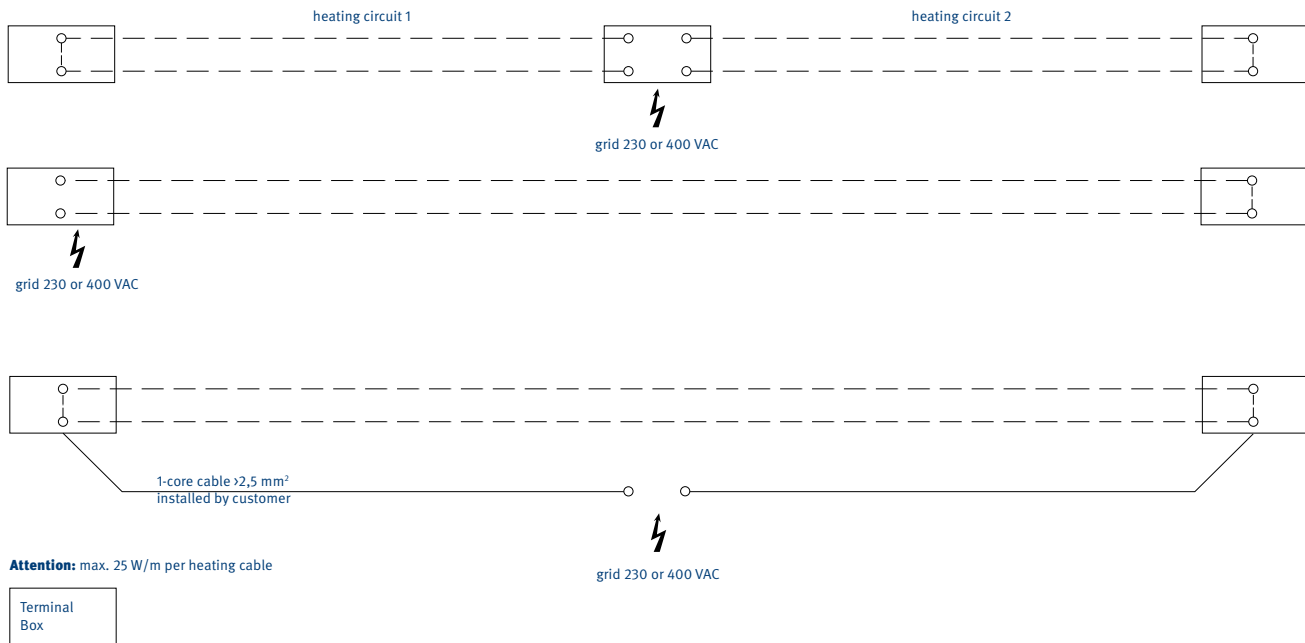

CONNECTING BOXES FOR HEATING

Type	DESIGN	Cable gland (Dimensions see p. 34)	Order No.
BH AKB MKH L	Left end	M 20	262 037
BH AKB MKH R	Right end	M 20	262 038
BH AKB MKH M	Line feed	2 x M 20	262 039
BH MA KBH MKL/H LSV G	1 set material for connecting clamps		195 291

For each end feed box, 2 sets of material for connecting ends are required.

Line feeds need 4 sets of material for connection ends.

Order for 60 m conductor system (example)

- 1) 122 m heating cable type H 2,0
(2 x 60 m and 2 x 1 m additional)
Voltage 400V, two heating circuits in parallel heating capacity as per above mentioned diagram
 $2 \times 22 \text{ W/m at } 60 \text{ m } 2 \times 22 \text{ W/m} \sim 2640 \text{ W} = 2,64 \text{ kW.}$
- 2) 1x Junction box left end
1x Junction box right end
- 3) 4x sets of material for connection ends.

Switch gear assembly and temperature control unit as per customer's inquiry.

Fuses, cables etc. have to be provided by the customer.

CONTACT SECTIONS, TURNTABLES & SWITCHES

Contact section ⁽¹⁾

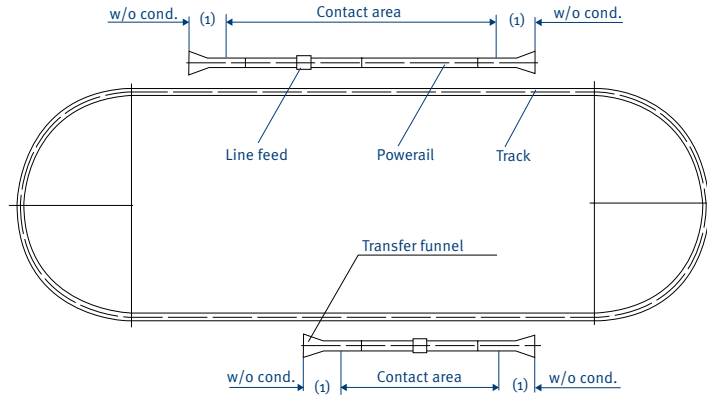

Turntable

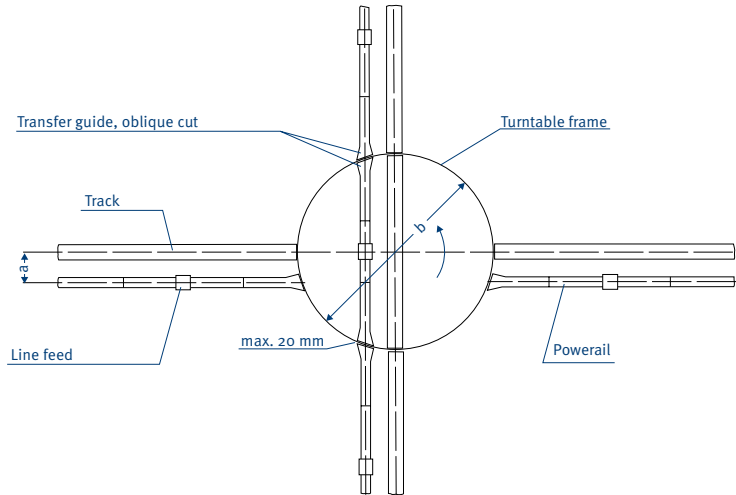

Sliding Switch

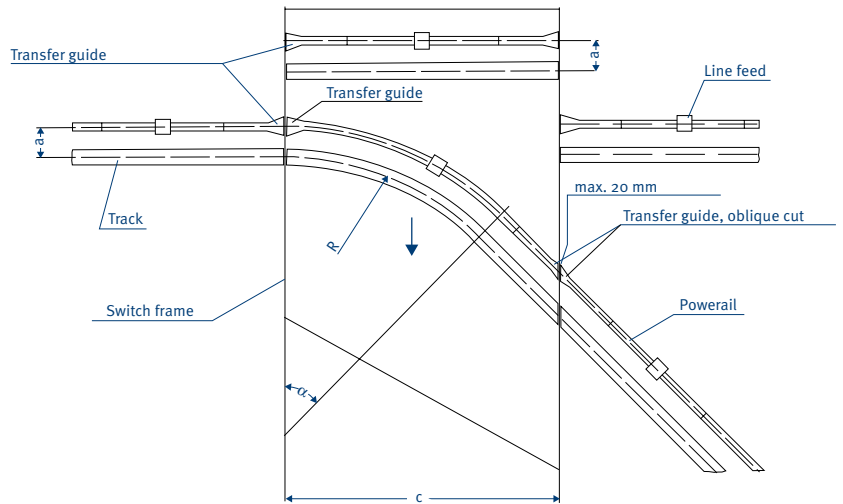

Please submit drawings of transfer applications.
Specify dimensions a, b, c, R, and angle α ($\alpha = \text{max. } 50^\circ$)
Max. 20 mm air gap between transfer guides.

To create all components for contact sections, turntables and switches, we require detailed construction drawings.

(1) Contact sections must not be activated before collectors are fully engaged.

ENTRY FUNNEL

Powerail should not be activated before the collector carbons have complete contact with the conductors.

Offset of the funnel/guide to the collector:

- Max. 10 mm horizontal
- Max. 10 mm vertical
- Max. speed for crossover of the current collector 60 m/min.

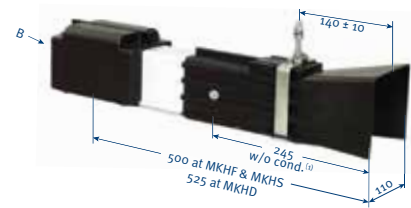
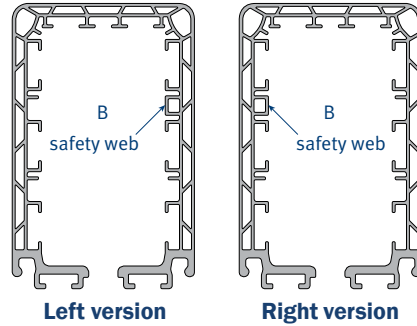

Type	Weight kg (lbs)	Order No. / Version	
		Left	Right
MTH 6/63-100 HS ⁽²⁾	2.018 (4.4)	262 375	262 387
MTH 7/63-100 HS ⁽²⁾	2.089 (4.6)	262 376	262 388
MTH 8/63-100 HS ⁽²⁾	2.160 (4.8)	262 377	262 389
MTH 6/140-160 HS	2.029 (4.5)	262 378	262 390
MTH 7/140-160 HS	2.100 (4.6)	262 379	262 391
MTH 8/140-160 HS	2.171 (4.8)	262 380	262 392
MTH 6/200 HS	2.082 (4.6)	262 384	262 396
MTH 7/200 HS	2.153 (4.7)	262 385	262 397
MTH 8/200 HS	2.224 (4.9)	262 386	262 398
MTH 6/63 SS ⁽²⁾	2.006 (4.4)	262 381	262 393
MTH 7/63 SS ⁽²⁾	2.075 (4.6)	262 382	262 394
MTH 8/63 SS ⁽²⁾	2.144 (4.7)	262 383	262 395

(1) Corresponding to the center of collector

(2) Also suitable for former 40 A version

TRANSFER GUIDES

TRANSFER GUIDES, STRAIGHT

Necessary with all types of double collectors or 2 single collectors.

Staggered arrangement of the transfer guides to each other:

- Max. 5 mm horizontal
- Max 3 mm vertical
- Max. speed for crossover of the current collector 80 m/min

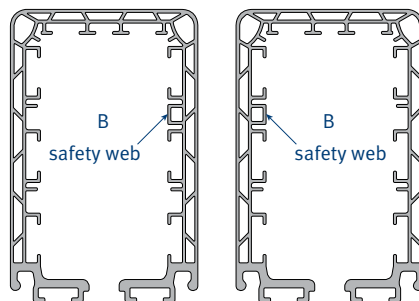

Left version

Right version



Type	Weight kg (lbs)	Order No. / Version	
		Left	Right
MUH 6/63-100 HS ⁽²⁾	2.005 (4.4)	262 399	262 408
MUH 7/63-100 HS ⁽²⁾	2.077 (4.6)	262 400	262 409
MUH 8/63-100 HS ⁽²⁾	2.119 (4.7)	262 401	262 410
MUH 6/140-160 HS	2.020 (4.5)	262 402	262 411
MUH 7/140-160 HS	2.092 (4.6)	262 403	262 412
MUH 8/140-160 HS	2.134 (4.7)	262 404	262 413
MUH 6/200 HS	2.092 (4.6)	262 417	262 420
MUH 7/200 HS	2.164 (4.8)	262 418	262 421
MUH 8/200 HS	2.236 (5.0)	262 419	262 422
MUH 6/63 SS ⁽²⁾	1.986 (4.4)	262 405	262 414
MUH 7/63 SS ⁽²⁾	2.055 (4.5)	262 406	262 415
MUH 8/63 SS ⁽²⁾	2.124 (4.7)	262 407	262 416

(1) Corresponding to the center of collector

(2) Also suitable for former 40 A version

TRANSFER GUIDES

TRANSFER GUIDES,

OBLIQUE⁽¹⁾

Necessary with all types of double collectors or 2 single collectors.

Staggered arrangement of the transfer guides to each other:

- Max. 5 mm horizontal
- Max 3 mm vertical
- Max. speed for crossover of the current collector 80 m/min

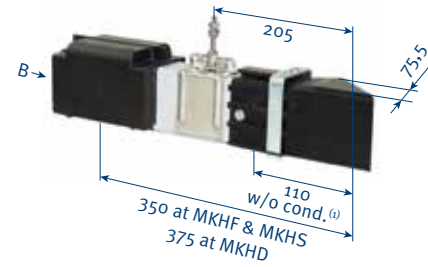
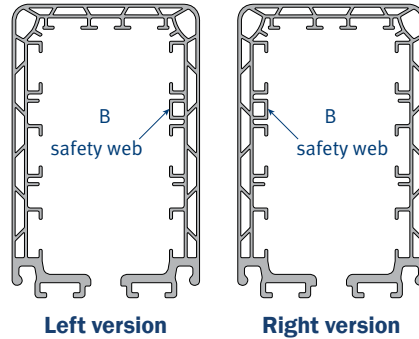

Type	Weight kg (lbs)	Order No. / Version	
		Left	Right
MUHS 6/63-100 HS ⁽²⁾	2.017 (4.4)	262 423	262 432
MUHS 7/63-100 HS ⁽²⁾	2.082 (4.6)	262 424	262 433
MUHS 8/63-100 HS ⁽²⁾	2.147 (4.7)	262 425	262 434
MUHS 6/140-160 HS	2.032 (4.5)	262 426	262 435
MUHS 7/140-160 HS	2.097 (4.6)	262 427	262 436
MUHS 8/140-160 HS	2.162 (4.8)	262 428	262 437
MUHS 6/200 HS	2.050 (4.5)	262 441	262 444
MUHS 7/200 HS	2.115 (4.7)	262 442	262 445
MUHS 8/200 HS	2.180 (4.8)	262 443	262 446
MUHS 6/63 SS ⁽²⁾	2.020 (4.5)	262 429	262 438
MUHS 7/63 SS ⁽²⁾	2.085 (4.6)	262 430	262 439
MUHS 8/63 SS ⁽²⁾	2.150 (4.7)	262 431	262 440

(1) Corresponding to the center of collector

(2) Also suitable for former 40 A version

REMOVAL SECTIONS

Assembly and disassembly of the collector is possible at the end of the track as well as at the removal section. By opening and closing the sliders at the bottom of the conductor housing the collector can be mounted and removed easily.

Before opening, disconnect mains. The removal section does not disconnect the powerail electrically.

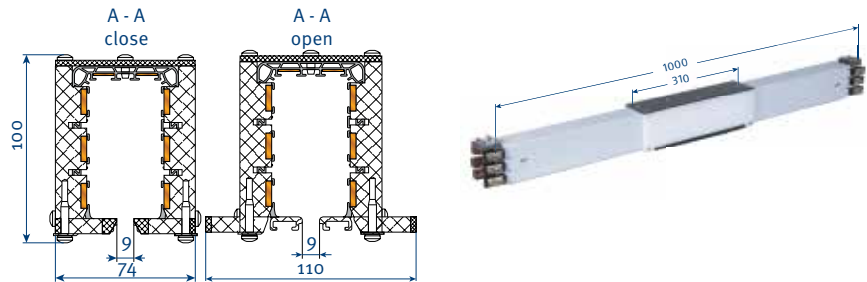

FOR SINGLE COLLECTORS

Type	Weight kg (lbs)	Order No.
MATH 6/63-100 HS ⁽¹⁾	4.392 (9.7)	262 147
MATH 7/63-100 HS ⁽¹⁾	4.568 (10.1)	262 148
MATH 8/63-100 HS ⁽¹⁾	4.744 (10.5)	262 149
MATH 6/140-160 HS	4.422 (9.7)	262 150
MATH 7/140-160 HS	4.598 (10.1)	262 151
MATH 8/140-160 HS	4.774 (10.5)	262 152
MATH 6/200 HS	4.652 (10.3)	262 156
MATH 7/200 HS	4.828 (10.6)	262 157
MATH 8/200 HS	5.004 (11.0)	262 158
MATH 6/63 SS ⁽¹⁾	4.404 (9.7)	262 153
MATH 7/63 SS ⁽¹⁾	4.580 (10.1)	262 154
MATH 8/63 SS ⁽¹⁾	4.756 (10.5)	262 155

FOR DOUBLE COLLECTORS

Type	Weight kg (lbs)	Order No.
MATHD 6/63-100 HS ⁽¹⁾	5.108 (11.3)	262 159
MATHD 7/63-100 HS ⁽¹⁾	5.284 (11.6)	262 160
MATHD 8/63-100 HS ⁽¹⁾	5.460 (12.0)	262 161
MATHD 6/140-160 HS	5.138 (11.3)	262 162
MATHD 7/140-160 HS	5.314 (11.7)	262 163
MATHD 8/140-160 HS	5.490 (12.1)	262 164
MATHD 6/200 HS	5.352 (11.8)	262 168
MATHD 7/200 HS	5.528 (12.2)	262 169
MATHD 8/200 HS	5.704 (12.6)	262 170
MATHD 6/63 SS ⁽¹⁾	5.116 (11.3)	262 165
MATHD 7/63 SS ⁽¹⁾	5.291 (11.7)	262 166
MATHD 8/63 SS ⁽¹⁾	5.468 (12.1)	262 167

(1) Also suitable for former 40 A version

MAINTENANCE SECTION

For maintenance work with MKH systems, collector removal and/or conductor bar replacement, maintenance sections conveniently drop out or reinstall at existing runway installations.

To obtain optimal accessibility on longer runways we recommend installing several maintenance repair sections at convenient intervals or locations.



FOR SINGLE COLLECTORS

Type	Weight kg (lbs)	Order - No.
MRT 6/63	7.104 (15.7)	263 265
MRT 7/63	7.539 (16.6)	263 266
MRT 8/63	7.974 (17.6)	263 267
MRT 6/80	8.032 (17.7)	263 268
MRT 7/80	8.467 (18.7)	263 269
MRT 8/80	8.902 (19.6)	263 270
MRT 6/100	9.339 (20.6)	263 014
MRT 7/100	9.774 (21.5)	263 015
MRT 8/100	10.209 (22.5)	263 016
MRT 6/140	10.047 (22.1)	263 017
MRT 67/140	10.482 (23.1)	263 018
MRT 8/140	10.917 (24.1)	263 019
MRT 6/160	11.019 (24.3)	263 020
MRT 7/160	11.454 (25.3)	263 021
MRT 8/160	11.889 (26.2)	263 022
MRT 6/200	12.003 (26.5)	263 023
MRT 7/200	12.430 (27.4)	263 024
MRT 8/200	12.873 (28.4)	263 025
MRT 6/63	7.104 (15.7)	263 275
MRT 7/63	7.539 (16.6)	263 276
MRT 8/63	7.974 (17.6)	263 277

(1) Standard length = 4000mm: any other length and maintenance sections in curves on request

CONDUCTOR DEAD SECTIONS

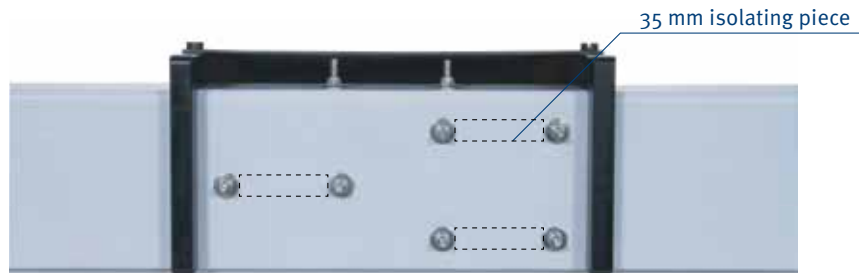

5 MM AIR GAP

Type ⁽¹⁾	Weight kg (lbs)	Order - No.
MHTL 1	0.238 (0.5)	262 578
MHTL 2	0.246 (0.5)	262 579
MHTL 3	0.254 (0.6)	262 580
MHTL 4	0.262 (0.6)	262 581
MHTL 5	0.270 (0.6)	262 582
MHTL 6	0.278 (0.6)	262 583
MHTL 7	0.286 (0.6)	262 584
MHTL 8	0.294 (0.6)	262 585

35 MM ISOLATING PIECE

Type ⁽¹⁾	Weight kg (lbs)	Order - No.
MHTI 1	0.274 (0.6)	262 586
MHTI 2	0.294 (0.6)	262 587
MHTI 3	0.309 (0.7)	262 588
MHTI 4	0.324 (0.7)	262 589
MHTI 5	0.339 (0.7)	262 590
MHTI 6	0.354 (0.8)	262 591
MHTI 7	0.369 (0.8)	262 592
MHTI 8	0.384 (0.8)	262 593
MHTI 9	0.387 (0.9)	262 594
MHTI 10	0.390 (0.9)	262 595

Please advise us which conductors should be disconnected (see Pages 8 and 9). The dead section comes factory assembled.

(1) Complete types e.g. ST-MHTI4HS-L1/L2/L3/2-MSWA for a 35 mm Isolating piece with separation of conductors L1, L2, L3 and 2 for the current collector MSWA → Order-No.: 262589

ANTI-CONDENSATION SECTION

The anti-condensation section consists of a 1 meter conductor bar section with air circulation holes, covered by a protection hood.

The anti-condensation section does not interrupt the system electrically.

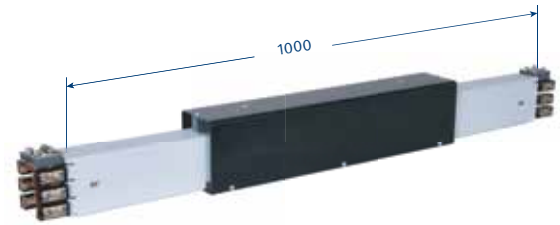

USE OF THE ANTI-CONDENSATION SECTION

Allows warm air to escape the housing. This prevents the build up of condensation inside the housing and the build up of ice outside the housing.

FEEDING

No extra feeds required as the conductor is not interrupted.

COLLECTORS

No extra collectors required.

INSTALLATION

Installed at transition areas where the system transitions from indoor to outdoor and vice versa.

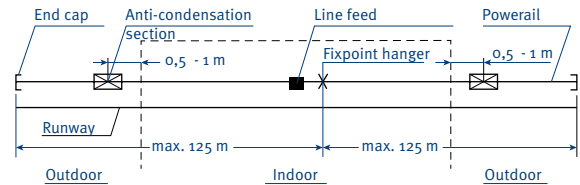

Type	Weight kg (lbs)	Order-No.
MBHD 6-10 HS	2.081 (4.6)	262 570
MBHD 6-10 SS	2.081 (4.6)	262 571

Type	Weight kg (lbs)	Order-No.
MBHS 6/63-100 HS ⁽¹⁾	4.678 (10.3)	262 135
MBHS 7/63-100 HS ⁽¹⁾	4.854 (10.7)	262 136
MBHS 8/63-100 HS ⁽¹⁾	5.030 (11.1)	262 137
MBHS 6/140-160 HS	4.708 (10.4)	262 138
MBHS 7/140-160 HS	4.884 (10.8)	262 139
MBHS 8/140-160 HS	5.060 (11.2)	262 140
MBHS 6/200 HS	4.954 (10.9)	262 144
MBHS 7/200 HS	5.130 (11.3)	262 145
MBHS 8/200 HS	5.306 (11.7)	262 146
MBHS 6/63 SS ⁽¹⁾	4.730 (10.4)	262 141
MBHS 7/63 SS ⁽¹⁾	4.906 (10.8)	262 142
MBHS 8/63 SS ⁽¹⁾	5.082 (11.2)	262 143

(1) Also suitable for former 40A - version

EXPANSION SECTIONS

Expansion sections are required to compensate for the different expansions between copper conductors and steel or concrete structures in varying temperatures, without interrupting electrical power. Expansion joints are used when the powerail length between feeds, curves, switches or other fix points is exceeding 10 m.

Max. length during differences in temperature:

- $\Delta t 20\text{ }^{\circ}\text{C} = 70\text{ m}$ $\Delta t 40\text{ }^{\circ}\text{C} = 35\text{ m}$ $\Delta t 80\text{ }^{\circ}\text{C} = 17\text{ m}$
- $\Delta t 30\text{ }^{\circ}\text{C} = 45\text{ m}$ $\Delta t 60\text{ }^{\circ}\text{C} = 23\text{ m}$

Longer runs or higher differences in temperature require more expansion joints.

- X = max. 55 m for outdoor systems
- X = max. 100 m for indoor systems

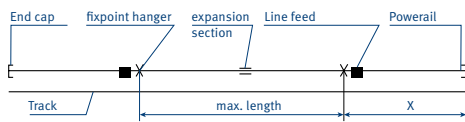

MKHD TYPES

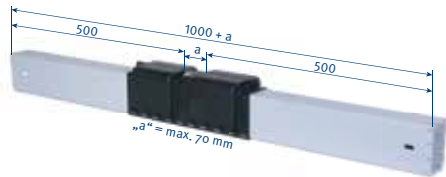
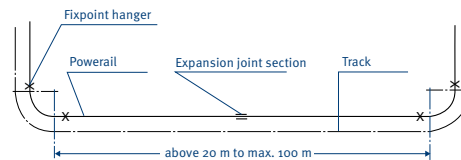

Photo shows MDHD



MKHF/S TYPES

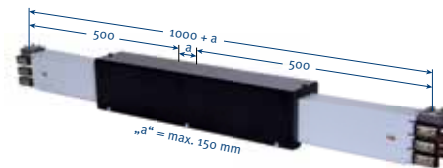

Photo shows MDHS

Type	Weight kg (lbs)	Order-No.
MDHD 6-8HS	1.424 (3.1)	262 572
MDHD 9HS	1.418 (3.1)	262 573
MDHD 10HS	1.412 (3.1)	262 574
MDHD 6-8SS	1.424 (3.1)	262 575
MDHD 9SS	1.418 (3.1)	262 576
MDHD 10SS	1.412 (3.1)	262 577

Type	Weight kg (lbs)	Order-No.
MDHS 6/63-100HS ⁽¹⁾	6.354 (14.0)	262 004
MDHS 7/63-100HS ⁽¹⁾	6.619 (14.6)	262 005
MDHS 8/63-100HS ⁽¹⁾	6.884 (15.2)	262 006
MDHS 6/140-160HS	6.384 (14.1)	262 007
MDHS 7/140-160HS	6.649 (14.7)	262 008
MDHS 8/140-160HS	6.914 (15.2)	262 009
MDHS 6/200HS	6.564 (14.5)	262 013
MDHS 7/200HS	6.829 (15.1)	262 014
MDHS 8/200HS	7.094 (15.6)	262 015
MDHS 6/63SS ⁽¹⁾	6.638 (14.6)	262 010
MDHS 7/63SS ⁽¹⁾	6.633 (14.6)	262 011
MDHS 8/63SS ⁽¹⁾	6.898 (15.2)	262 012

(1) Also suitable for former 40 A - version

APOS POSITIONING SYSTEM

Developed for automated handling systems in material flow technology, the control system can constantly query the absolute position of the mobile consumer. Integrating into the bottom outer shafts of the MKH housing, VAHLE APOS offers a compact and all in one power and positioning solution.

FEATURES

- Absolute position determination up to 262 m
- Seamless integration into the MKH Conductor Bar housing for space-saving solutions or for installation parallel to the runway
- Retrofittable
- Absolute position immediately available when switching on or after a power failure
- Reliable position detection even in humid or dusty environments
- Trouble-free functionality even in poor lighting conditions
- Travel speed up to 250 m/min
- No wear (contactless)

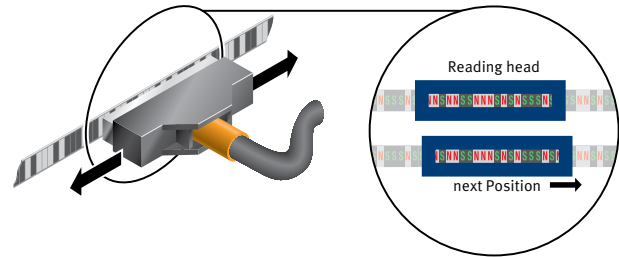
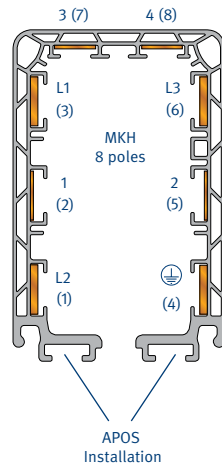

**For more information see our catalog
VAHLE APOS®.**

COLLECTORS

SINGLE COLLECTOR MSWA

Max. speed 180m/min. or 100m/min for conductor bar with sealing strip

CONNECTING CABLES:

- For power line: cable 1 → 4 x 6 mm²
cable 2 → ... x 1.5 mm²
- For control line: cable 1 → ... x 2.5 mm²
(two cables for 8-pole and more)
- For curves use single collectors only
- Connecting cable 1 m, longer cable available

Cleaning trolleys on request

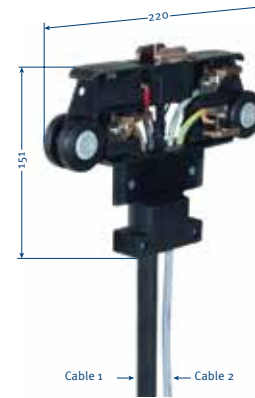

Example of ordering double collectors with 2 m cable: Order - No. 236 177.2 for collector MSWA 6/50-2 HS

Type	Weight kg (lbs)	No. of conductors	Power rating at 60% DC in A	Ø of connecting cables in mm		Order-No.
				Cable 1	Cable 2	
MSWA 6/50-1 HS	1.254 (2.8)	6	50	≈ 17.0	≈ 7.0	236 177.1
MSWA 7/50-1 HS	1.307 (2.9)	7	50	≈ 17.0	≈ 7.5	236 178.1
MSWA 8/50-1 HS	1.369 (3.0)	8	50	≈ 17.0	≈ 8.0	236 179.1
MSWA 9/50-1 HS	1.484 (3.3)	9	50	≈ 17.0	≈ 9.0	236 180.1
MSWA 10/50-1 HS	1.592 (3.5)	10	50	≈ 17.0	≈ 9.5	236 181.1
MSWA 6/25-1 SS	0.922 (2.0)	6	25	≈ 11.5	-	236 182.1
MSWA 7/25-1 SS	0.958 (2.1)	7	25	≈ 11.5	-	236 183.1
MSWA 8/25-1 SS	1.030 (2.3)	8	25	≈ 10.0	≈ 10.0	236 184.1
MSWA 9/25-1 SS	1.158 (2.6)	9	25	≈ 11.0	≈ 10.0	236 185.1
MSWA 10/25-1 SS	1.347 (3.0)	10	25	≈ 11.5	≈ 10.0	236 186.1

COLLECTORS

SINGLE COLLECTOR MSWAS

Max. speed 250 m/min. or 100 m/min. on conductor bar with sealing strip

CONNECTING CABLES:

- For power line: cable 1 → 4 x 6 mm²
cable 2 → ... x 1,5 mm²
- For control line: cable 1 → ... x 2,5 mm²
(two cables for 8-pole and more)
- For curves use single collectors only
- Connecting cable 1 m, longer cable available

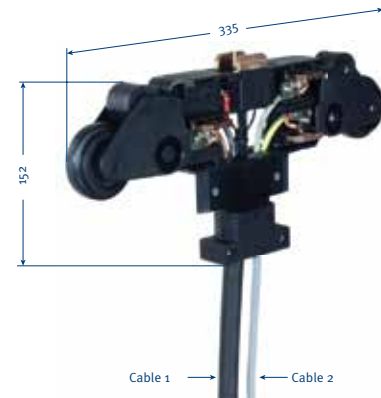

Example of ordering double collectors with 2 m cable: Order - No. 236 200.2 for collector MSWAS 6/50-2 HS

Type	Weight kg (lbs)	No. of conductors	Power rating at 60% DC in A	ø of connecting cables in mm		Order - No.
				Cable 1	Cable 2	
MSWAS 6/50-1 HS	1.354 (3.0)	6	50	≈ 17.0	≈ 7.0	236 200.1
MSWAS 7/50-1 HS	1.407 (3.1)	7	50	≈ 17.0	≈ 7.5	236 201.1
MSWAS 8/50-1 HS	1.469 (3.2)	8	50	≈ 17.0	≈ 8.0	236 202.1
MSWAS 9/50-1 HS	1.584 (3.5)	9	50	≈ 17.0	≈ 9.0	236 203.1
MSWAS 10/50-1 HS	1.692 (3.7)	10	50	≈ 17.0	≈ 9.5	236 204.1
MSWAS 6/25-1 SS	1.622 (3.6)	6	25	≈ 11.5	-	236 205.1
MSWAS 7/25-1 SS	1.058 (2.3)	7	25	≈ 11.5	-	236 206.1
MSWAS 8/25-1 SS	1.130 (2.5)	8	25	≈ 10.0	≈ 10.0	236 207.1
MSWAS 9/25-1 SS	1.258 (2.8)	9	25	≈ 11.0	≈ 10.0	236 208.1
MSWAS 10/25-1 SS	1.447 (3.2)	10	25	≈ 11.5	≈ 10.0	236 209.1

COLLECTORS

DOUBLE COLLECTOR DMSWA

- Max. speed 180m/min. or 100m/min. for conductor bar with sealing strip

CONNECTING CABLES:

- For power line: cable 1 → 4 x 6 mm²
cable 2 → ... x 1.5 mm²
- For control line: cable 1 → ... x 2.5 mm²

(two cables for 8-pole and more)

- For curves use single collectors only
- Connecting cable 1 m, longer cable available

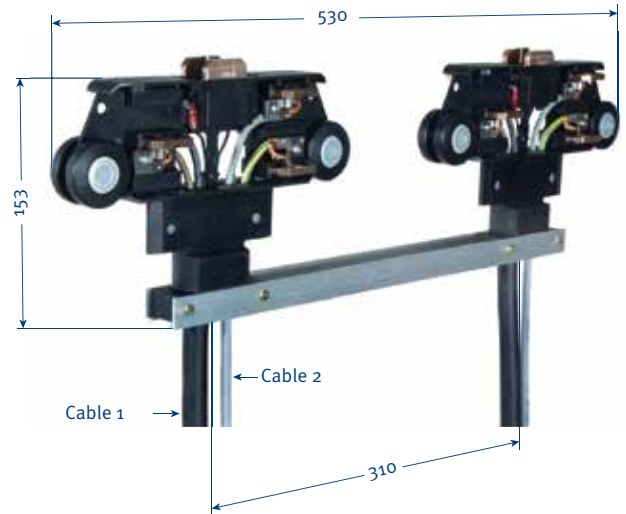

Example of ordering collector with 2 m cable: Order - No. 236 315.2 for collector DMSWA 6/100S-2 HS

Type	Weight kg (lbs)	No. of conductors	Power rating at 60% DC in A	Ø of connecting cables in mm		Order - No.
				Cable 1	Cable 2	
DMSWA 6/100S-1 HS	2.670 (5.9)	6	100	≈ 17.0	≈ 7.0	236 315.1
DMSWA 7/100S-1 HS	2.776 (6.1)	7	100	≈ 17.0	≈ 7.5	236 316.1
DMSWA 8/100S-1 HS	2.900 (6.4)	8	100	≈ 17.0	≈ 8.0	236 317.1
DMSWA 9/100S-1 HS	3.130 (6.9)	9	100	≈ 17.0	≈ 9.0	236 318.1
DMSWA 10/100S-1 HS	3.346 (7.4)	10	100	≈ 17.0	≈ 9.5	236 319.1
DMSWA 6/50S-1 HS	2.006 (4.4)	6	50	≈ 11.5	-	236 320.1
DMSWA 7/50S-1 HS	2.078 (4.6)	7	50	≈ 11.5	-	236 321.1
DMSWA 8/50S-1 HS	2.222 (4.9)	8	50	≈ 10.0	≈ 10.0	236 322.1
DMSWA 9/50S-1 HS	2.478 (5.5)	9	50	≈ 11.0	≈ 10.0	236 323.1
DMSWA 10/50S-1 HS	2.856 (6.3)	10	50	≈ 11.5	≈ 10.0	236 324.1

TOW ARMS

TOW ARM

Installation options of 30 mm square (hollow profile or tube) with 30-34 mm.

A - A Version with square hollow profile (without adapter plate)



A - A version with tube ⁽¹⁾

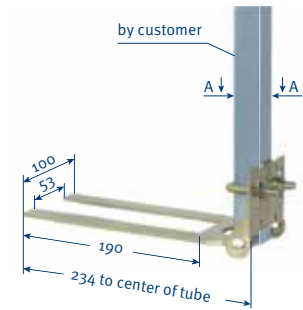

Type	Weight kg (lbs)	Order - No.
MGUN	0.632 (1.4)	600 887
MGU/K ⁽²⁾	0.550 (1.2)	600 336

TOW ARM

For plane surface

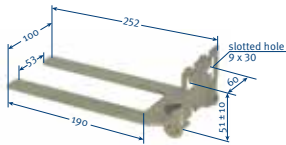

Type	Weight kg (lbs)	Order - No.
MGFN	0.524 (1.2)	600 888
MGF/K ⁽²⁾	0.442 (1.0)	600 337

FLEXIBLE TOW ARM

For single collectors – flexible support type for systems with transfer funnels MTH. If you are going to use the flexible towing arm in system with curves, please contact us.

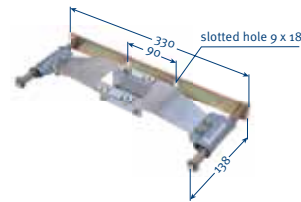

Type	Weight kg (lbs)	Order - No.
MFMN	1.021 (2.3)	236 400

FLEXIBLE TOW ARM CONFIGURATION

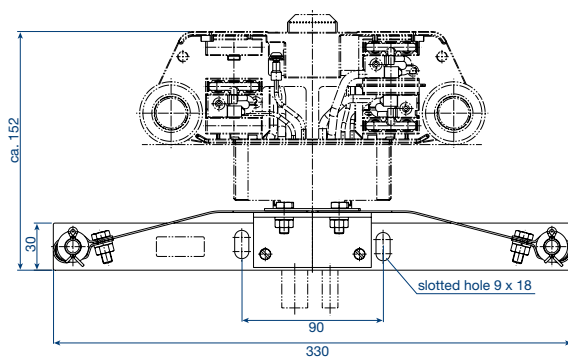

Max. horizontal offset 15 mm

Max. vertical offset 10 mm

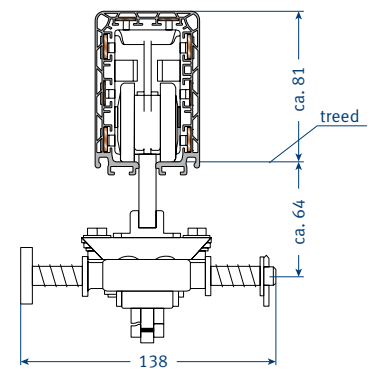

(1) For assembly, use enclosed adapter plate.

(2) .../K Stainless Steel

FLAT COPPER & CABLE GLANDS

FLAT COPPER (MKHD)

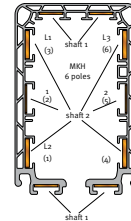

MAX. LENGTH OF 11 MM WIDE STRIP (FOR SHAFT 1)

Type	Description	Weight kg/m (lbs.)	Type of cassette			Order - No. (Cu)	Order - No. (Inox)
			A	B	C		
SS-FLCU40A/11-11X1-E	11 mm ² 11 x 1mm (40 A)	0.10 (0.2)	90	260	300	234 198	-
SS-INOX40A/11-11X1-E	11mm ² 11 x 1 mm	0.09 (0.2)	90	260	300	-	234 384

MAX. LENGTH OF 13 MM WIDE STRIP (FOR SHAFT 1)

Type	Description	Weight kg/m (lbs.)	Type of cassette			Order - No. (Cu)	Order - No. (Inox)
			A	B	C		
SS-FLCU40A/10-13X0.8-E	10mm ² 13 x 0.8 mm (63 A)	0.09 (0.2)	115	300	-	234 197	-
SS-FLCU80A/17-13X1.3-E	17mm ² 13 x 1.3 mm (80A)	0.15 (0.3)	65	200	300	234 199	-
SS-INOX40A/17-13x1.3-E	17mm ² 13 x 1.3 mm	0.14 (0.3)	65	200	300	-	234 383
SS-FLCU100A/26-13X2-E	26mm ² 13 x 2 mm (100 A) ⁽²⁾	0.23 (0.5)	45	130	200	234 200	-
SS-FLCU140A/33-13X2.5-E	33mm ² 13 x 2.5 mm (140 A) ⁽²⁾	0.29 (0.6)	35	100	160	234 201	-
SS-FLCU160A/42-13X3.2-E	42mm ² 13 x 3.2 mm (160 A) ⁽²⁾	0.37 (0.8)	25	80 ⁽¹⁾	120 ⁽¹⁾	234 202	-

CABLE GLANDS

Cable glands	For cable- ϕ in mm	Capacity A (execution: D/F/S)	Page
M 25 and M 40	11-17 and 19-28	63-80 HS	S. 12, 13
M 25	11-17	63 SS	S. 12, 13
M 25 and M 50	9-19 and 23-24	63-100 HS	S. 13, 14
M 25 and M 50	9-19 and 29-40	163-200 HS	S. 13, 14
M 25	9-19	63 SS	S. 13, 14
M 25 for L1/L2/L3	9-19	63-200 HS	S. 15, 16
M 25 for 1-4 and 9/10	6-15	63-200 HS	S. 15, 16
M 25 6 to 10- poles	9-19	63 SS	S. 15, 16
M 20	6-13	63-200 SS/HS	S. 15, 16, 18

(1) Values for installation through VAHLE-engineers (with help device possible). Use bolted joints and possibly expansion sections for bigger lengths than shown in the table. In this case, installation by VAHLE experts is recommended, especially for copper cross section of 42 mm² and 51 mm². Consult factory for proper layout.

(2) With straightening tool (see page 35).

ASSEMBLING TOOLS

COPPER CASSETTES



Type	Weight kg (lbs.)	Dim. >>X<<	Dim. >>Y<<	Type of cassette	Order - No.
MZ-EZK1-MKL/H	2.364 (5.2)	462	500	A	234 219
MZ-EZK2-MKL/H	3.890 (8.6)	662	700	B	234 220
MZ-EZK3-MKL/H	5.648 (12.5)	862	900	C	234 250
MZ-DEZK1-MKL/H	4.831 (10.7)	462	500	A	234 221
MZ-DEZK2-MKL/H	7.883 (17)	662	700	B	234 222
MZ-DEZK3-MKL/H	11.387 (25.1)	862	900	C	234 251

Type of copper cassette depends on copper cross section and system length (see page 34).

STRAIGHTENING TOOL

Required from strip sections 26 mm² upwards

Type	Weight kg (lbs.)	Order - No.
MZ-RV-MKL/H	0.952 (2.1)	234 218

CONDUCTOR THREADING TOOL



Type	Weight kg (lbs.)	Description	Order - No.
MZ-EZR6-8-MKL/H	0.991 (2.2)	For conductors inside housing, shafts 1 & 2	234 204
MZ-EZR9/10-MKL/H	0.182 (0.4)	For conductors outside housing, shaft 1 only	234 730

EXAMPLE FOR ORDERING

- MKHF 8/100 HS & MKHS 8/100 (see page 8-9)
- 63.7 meter length MKH system with 8 conductors
- Per drawing

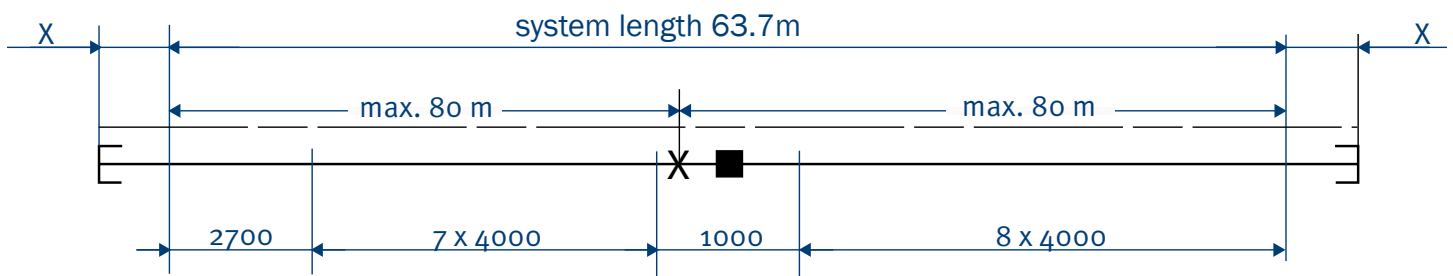

Quantity	Description	MKHF		MKHS	
		Type	Order - No.	Type	Order - No.
15	Conductor Bar, 4 meter length	MKHF 8/100	-	MKHS 8/100	-
1	Conductor Bar, 2.7 meter length	MKHF 8/100	-	MKHS 8/100	-
1	Line feed, 1 meter length	MHGF 8/100 HS	262 500	MHGS 8/100	262 456
2	End caps	MSES	235 141	MSES	235 141
16	Joint caps	MVMS	234 585	MVMS	234 585
1	Fixpoint hanger	MFH	262 001	MFH	262 001
32	Sliding hangers	MGH	262 000	MGH	262 000
1	Single collector	MSWA 8/50- 1 HS	236 179.1	MSWA 8/50- 1 HS	236 179.1
1	Tow arm	MGU	600 334	MGU	600 334

SPARE PARTS

FOR ENCLOSED CONDUCTOR SYSTEM

Type	Description	Order - No.
VM-STV11/40A-MKHF	Plug-in joint for MKHF (11 mm CU; 40A)	262 020
VM-STV13/63-100A-KBHF/MKHF ⁽¹⁾	Plug-in joint for MKHF (13mm CU; 63-100 A)	600 483
VM-SCHV11/40A-MKHS/MKLS	Bolted joint for MKHS (11 mm Cu; 40 A)	262 019
VM-SCHV13/63-200A-KBHS/MKHS/MKLS ⁽¹⁾	Bolted joint for MKHS (13 mm Cu; 63-200 A)	262 018
VM-MVMT-MT-MU/S-9/10POL	Joint Cap for transfer guide and transfer funnel, pair (MKHD, MKHF and MKHS)	234 779
DL-D-KBH-MKH-MKL-TDV	Sealing strip (max. length each 40 m)	600 551
DL-V-KSLT-KBH-MKL/H-LSV/G	Coupling for sealing strip, in pairs (2 per joint)	258 300
DL-F-MKL/H	Fixing clamp for sealing strip (1 per end)	236 105

FOR COLLECTOR MSWA

Type	Description	Order - No.
SK-KSW-MSWA-PH/SU-28	Carbon Phase (lateral, 9th and 10th pole)	600 088
SK-KSW-MSWA-PE/S-28	Carbon Ground (lateral, PE)	600 090
SK-MSWA-PH/O-28	Carbon top (7th and 8th pole)	236 187
SA-KF-KSW-MSWA-SP	Carbon spring standard (for all carbons, pair)	600 338
TR-MNSW/A-SF310	Rigid bar for DMSW & DMSWA	234 515
SA-ZB-AS-MSWA-P-250	High speed set for collector MSWAS	236 199
SA-ZB-DG-MSWA-S	Sealing strip slide plate for collectors MSWA	236 625

CLEANING ACCESSORIES ON REQUEST

(1) Also suitable for former 40A - version

QUESTIONNAIRE

Company: _____ Fax: _____
 Date: _____ Email: _____
 Phone: _____ Internet: _____

1. Number of conductor system installations: _____
2. Type of equipment to be powered: _____
3. Operating voltage: _____ Volt Frequency: _____ Hz
 Three phase voltage: AC voltage: DC voltage:
4. Track length: _____
5. Number of conductors: _____ neutral: _____ control: _____ ground: _____
6. Mounted position of conductor system:
 Conductor pendant / collector cable facing to the bottom Conductor pendant / collector cable lateral payout⁽¹⁾
 Support distance m (max. 2 m) Other: _____
7. Number of consumers per system: _____
8. Indoor: Outdoor:
9. Special operating conditions (humidity, dust, chemical influences etc.) _____
10. Ambient temperature: _____ °C min. _____ °C max. _____
11. Hall expansion joints: _____ pieces. min. _____ max. _____ expansion.
12. Position and number of feeding points⁽¹⁾: _____
13. Position and number of isolating sections (e.g. for maintenance⁽¹⁾): _____
14. How will the conductor system be arranged?⁽¹⁾: _____
15. Brackets required: yes ; no c/c distance beam / conductor system _____
 Flange width of beam: _____
16. Travel speed: _____ in curves: _____ at transfers: _____
17. Max. voltage drop from the conductor feed point to the consumer considering starting current:
 3% other _____ % referring to the nominal voltage.
18. Power consumption of the individual consumer loads: _____

Motor Data	Crane 1							Crane 2						
	Power kW	Nominal current			Starting current		Type of Motors ⁽²⁾	Power kW	Nominal current			Starting current		Type of Motors ⁽²⁾
		A	cos ΦN	% DC	A	cos ΦN			A	cos ΦN	% DC	A	cos ΦN	
Hoist motors														
Auxiliary hoist														
Long travel														
Cross travel														

Mark with * those motors which can run simultaneously

Mark with Δ those motors which can start up simultaneously

Further remarks: _____

Signature _____

(1) Sketches required for quotation

(2) Use: K for squirrel cage motor, S for slipring motor, F for frequency controlled motor

We reserve all rights to make alterations in the interest of further development.

Please copy and fill in the questionnaire.



SERVICE & SUPPORT

WE DEVELOP TAILOR-MADE SOLUTIONS FOR YOUR APPLICATIONS

The successful range of VAHLE systems is complemented by a comprehensive range of services tailored to meet our customers' requirements, including

- System design
- Project management
- Commissioning
- Engineering
- Installation & Installation supervising
- After-sales service
- Product training courses
- Maintenance packages

We will be glad to apply our expertise to develop specific solutions for your company. Give us a call and arrange for an appointment to learn more about VAHLE systems and services to meet your requirements.

VAHLE

VAHLE INC.

**1169 BRITTMOORE RD.
HOUSTON, TX 77043**

**TEL: 713-465-9796
E-MAIL: SALESINBOX@VAHLEINC.COM**

WWW.VAHLEINC.COM